

The operation manual for VT-5003BS20

Proportional amplifier VT-5003BS20 is used in the control of 3 way proportional pressure control valve with the spool position feedback 3DREP6 ... -10...24... .

I Technical data:

1. Power supply: 24V +10%-5%
2. Power: 50W
3. Control voltage: $\pm 9V \pm 2\%$
4. Max. output current: 2200mA
5. Oscillating frequency: 2.5KHZ
6. Load resistant: 10Ω
7. Ramp time: 0.02S-5S
8. Ambient temperature: 0-40°C

Remark: Abovementioned technical data has been preset. if you have special requirement, please clarify when ordering

II. How to use: Refer to connecting diagram

- Amplifier and external wiring connection

1. The electrical supply should be D.C.24V

The point 6A or 6C connected to the positive pole of the electrical supply.10A

or 10C connected to the negative pole of the electrical supply.

2. The connection of between the amplifier and solenoid.

The two ports of the proportional solenoid should be connected to 2A (or 2C) and 4 A (or 4C) separately.

Remark: there is no directionality in the wire connecting.

3. The connection with the bit shift sensor: the amplifier should be connected to the bit shift sensor with the shield cable.

20c should connect to the port 1 of the bit shift sensor.

14c should connect to the port 2 of the bit shift sensor.

22c should connect to the port \perp of the bit shift sensor.

4. The input of the control voltage signal

- (1). +9V control voltage (command electrical level) input port: through the external potentiometer (resistance: 5K-10K) input the voltage signal 0--+9V voltage signal from 26C.

- (2). +10V buffering simulated valve input port: programmable controller or

functional generator output the differential voltage should be input from port 22A and 24C. 22A connect to high level, 24C connect to low level. When the differential voltage up to 10V, it is corresponding to the Max. position of the spool.

Caution: never connect to 22A and 24C to any port of the

amplifier. It means that programmable controller (PLC) should not use the same power with the amplifier.

- The usage of the amplifier

1. This amplifier can supply +9V(16A, C) and -9V(14A or 26C) flat voltage. Besides self voltage supply, +9V can be supply voltage signal to external potentiometer.
2. When the differential motion signal from program controller (PLC) or the computer, the bit shift of the solenoid can be controlled by the 0-+10V voltage input from 22A and 24 C.
3. There is two pair of testing hole for nominal value (0-+6V) and real value (0- -6V), through voltage value of the testing hole for the nominal value, the monitoring for the input voltage can be realized. When the real value is zero, the spool should be zero position. When the real value is -6V, the spool should be at the Max.strock. . If the spool is in the middle, the real valve should be between the 0- -6V. The nominal value and the absolute value o the real value should be equivalence. It is also the way to test if the amplifier is work or not.
4. There are potentiometers that can adjust the ramp time, it can adjust the rise time and fall time separately. When the input voltage to the Max.value (+9V), the rise time is the Max. value. If no special requirement, the Max. ramp time is 5 second.

If the power unit do not need the ramp time

- (1). Counterclockwise rotate potentiometer for the ramp time to the minimum
 - (2). Switch on the relay, Short circuit the ramp circuit (short circuit 8A and 28A)
 - (3). Short circuit 30Cand 32C
 - (4).
5. If the amplifier and bit shift shut down or improper connection. The feedback shut down led light, the cable failure identification will key off the current in the solenoid.

III. Caution

1. If there is spool vibration, it is caused because there is air in the valve usually. You can pulse on the hydraulic circuit, open the air bleed screw, let the spool alternating motion till the air was exhausted.
2. The voltage of <MO> port (18A,C) is compared with the input voltage oV(10A, C) increase +9V, never short- circle them.

IV. This amplifier is European standard 32 pin (5.08X5.08mm). VT-3002B and VT1516B holder can match with this amplifier.

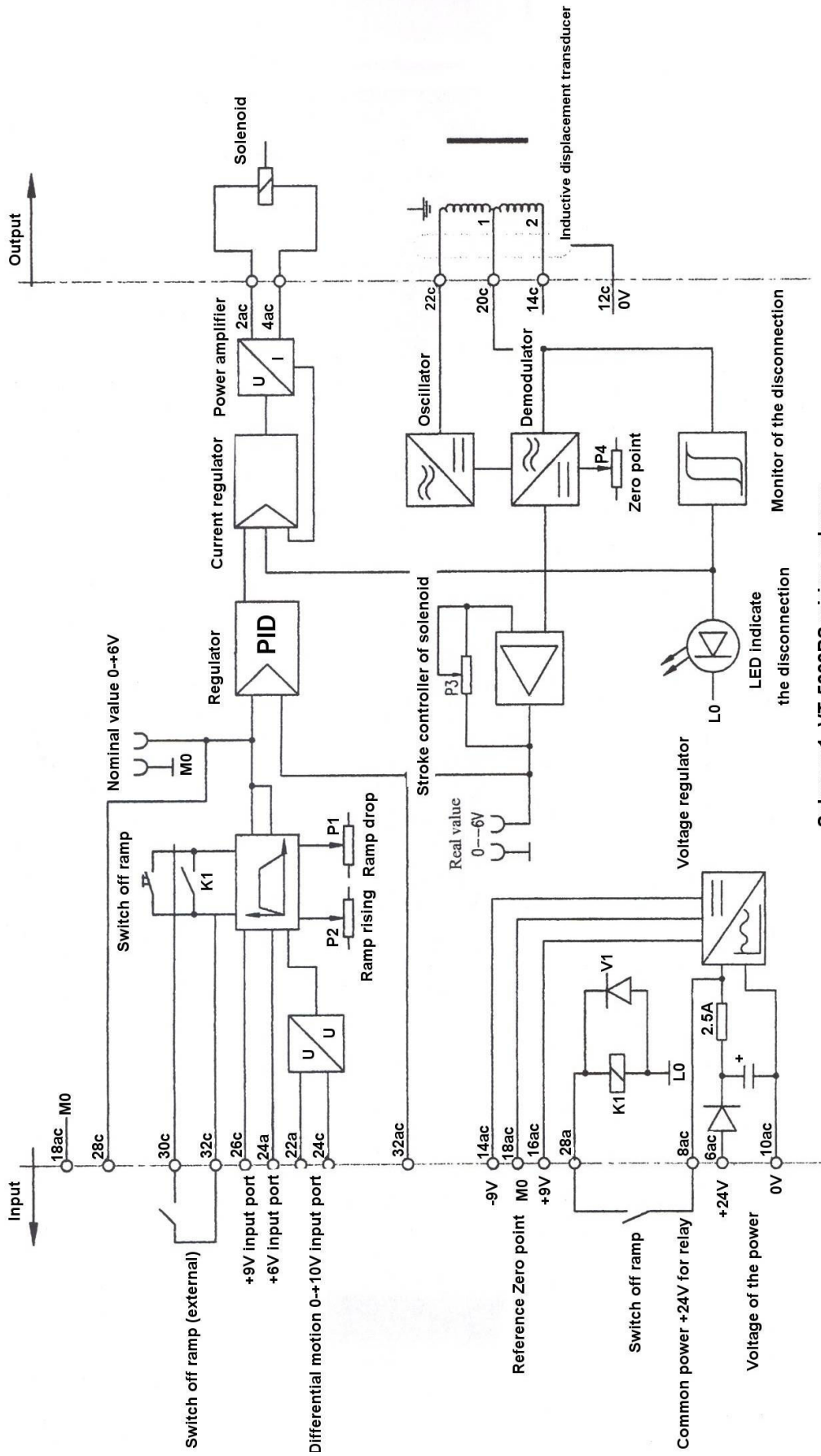

Scheme 1 VT-5003BS wiring scheme