



**Pressure gauge - Isolator valve, Type AF 6**

RE30060/12.2004

Size 6

up to 31.5MPa

Replaces:  
RE30060/05.2001

Pressure gauge isolator valves type AF 6 are 3-way longitudinal valves for manual operation. They serve to check the prevailing operating pressure from time to time. In the initial position, flow from P to the pressure gauge via the spool (2) is blocked and the pressure gauge is connected with T. When the button (4) is pushed, the spool (2) is moved into the switched position, giving free flow from P to the pressure gauge and the connection to T is blocked. By rotating the push button (4), the spool (2) can be locked in place via a detent. After operation, the spool (2) is pushed back into the initial position by the pressure spring (1) and thereby unloads the pressure gauge. The pressure gauge can be directly screwed in to the valve housing or fitted separately (see installation examples on page 58).



**Symbols**

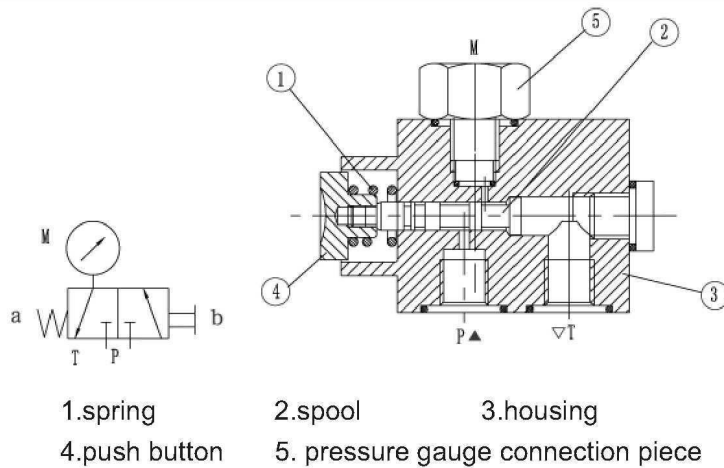

**Ordering details**

A	F	6	E		30	/	/	*
---	---	---	---	--	----	---	---	---

Isolator valve	= A	Further details in clear text
Spring return	= F	
Nominal size 6	= 6	
Single valve	= E	
For threaded connections	= A	
For subplate mounting	= P	No code= Mineral oil V= Phosphate ester
Series 30 to 39 (30 to 39: unchanged installation and connection dimensions)	= 30	63 = Indication range up to 6.3 MPa 100 = Indication range up to 10 MPa 160 = Indication range up to 16 MPa 250 = Indication range up to 25 MPa 400 = Indication range up to 40 MPa
		X = Without accessories Y = With accessories (connection piece, 2 seal rings and pressure gauge) Z = Complete with accessories (as Y with mounting plate)

**Unit dimensions**

**(Dimensions in mm)**

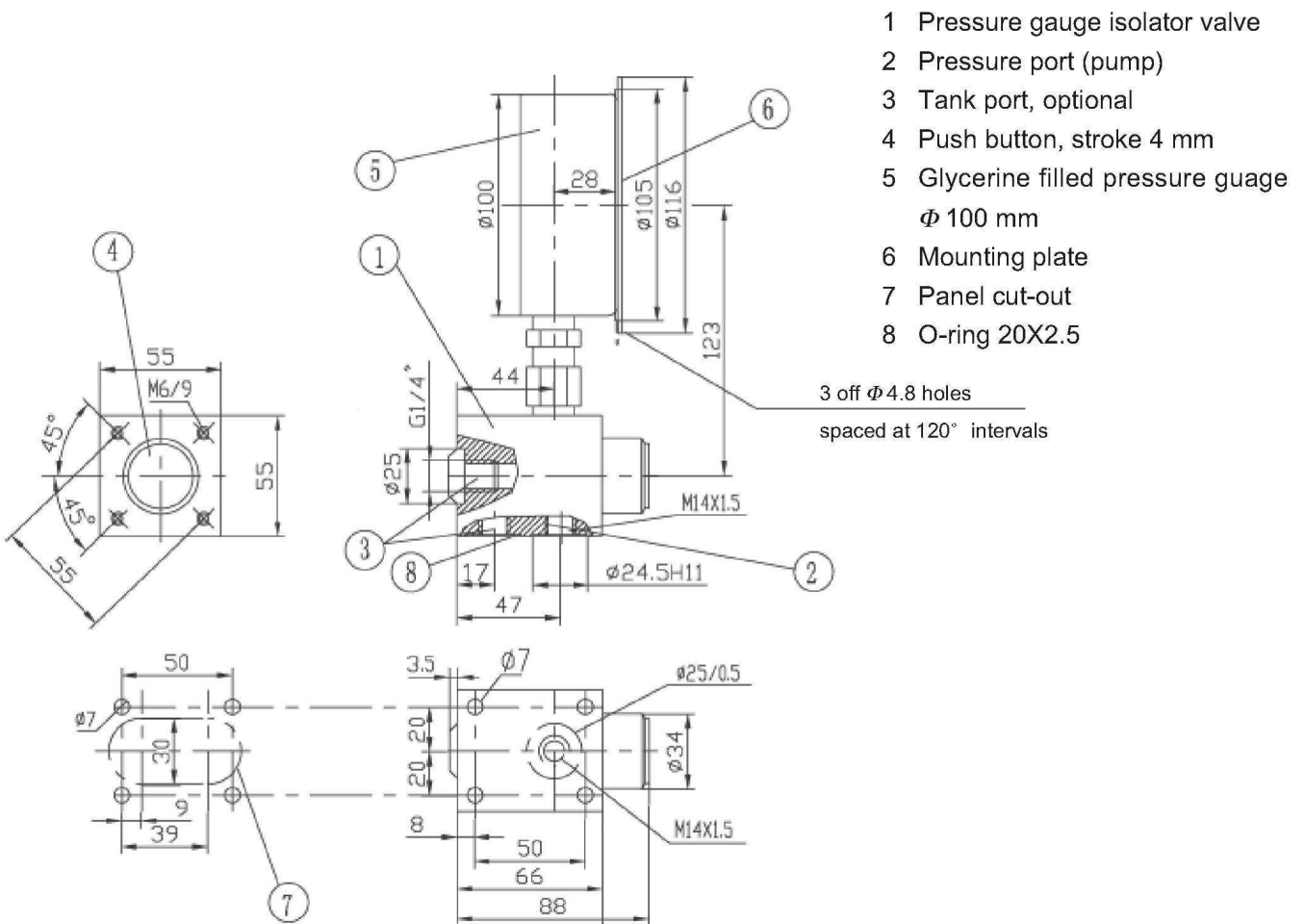

**Technical data** (for applications outside these parameters, please consult us!)

Max. operating pressure	to 31.5MPa	Pressure gauge indicating range	Up to 6.3, 10,16, 25, 40 (the indicating range should be approx. 30% above the max.operating pressure).
-------------------------	------------	---------------------------------	---

**Installation examples**

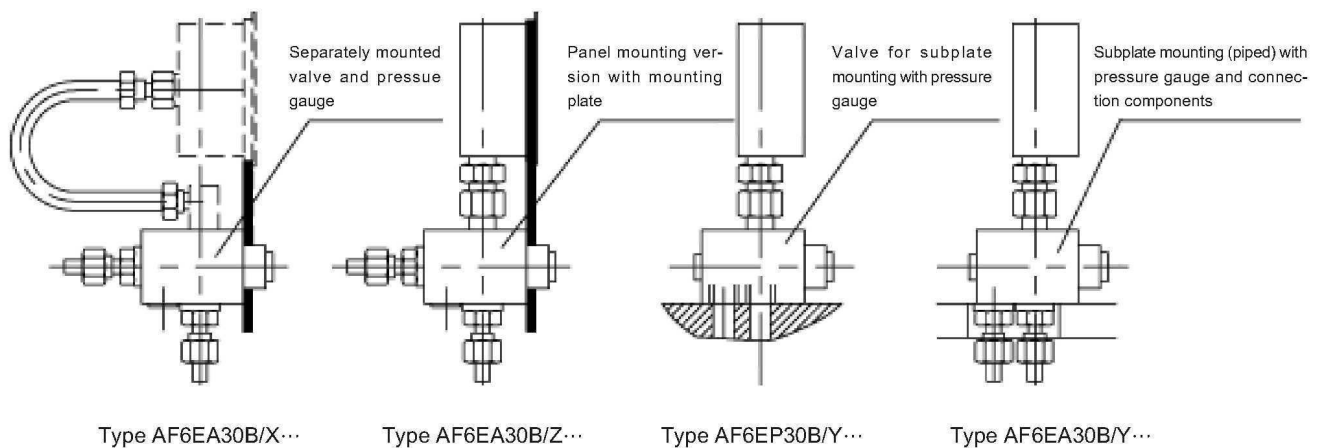

## Notice

1. The fluid must be filtered. Minimum filter fineness is 20  $\mu\text{m}$ .
2. The tank must be sealing up and an air filter must be installed on air entrance.
3. Products without subplate when leaving factory, if need them, please ordering specially.
4. Valve fixing screws must be high intensity level (class 10.9). Please select and use them according to the parameter listed in the sample book.
5. Roughness of surface linked with the valve is required to  $\frac{0.8}{\nabla}$ .
6. Surface finish of mating piece is required to 0.01/100mm.