



**Pressure shut-off valve, pilot operated,
type DA/DAW...-30B/**

RE 26410/12.2004

Size 10, 20, 30

up to 31.5 MPa

up to 250 L/min

Replaces:
RE26410/05.2001

Features:

- For subplate mounting:
- 4 adjustment elements:
 - Rotary knob
 - Sleeve with internal hexagon and protective cap
 - Lockable rotary knob with scale
 - Rotary knob with scale
- 3 pressure ratings
- Solenoid actuated unloading via a built-in directional valve

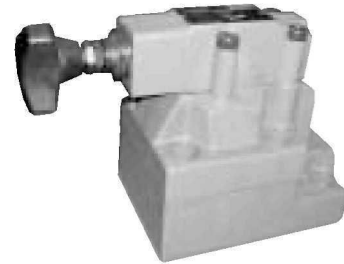

Function, section:

Pressure control valves type DA/DAW are pilot operated pressure shut-off valves.

They are used to switch a pump flow over to unpressurised by-pass as soon as the accumulator loading pressure is reached. Further applications for the valve are in systems that have high and low pressure pumps. In this case the low pressure pump is switched to unpressurised by-pass as soon as the set high pressure is reached.

Pressure shut-off valves basically consist of the main valve with the main spool assembly, pilot valve with pressure adjustment element and check valve. In size 10 valves, the check valve is built into the main valve. In valve sizes 25 and 32 the check valve is built into a separate plate installed under the main valve.

Pressure shut-off valve type DA

Diverting pump flow from P to A or P to T.

The pump delivers flow via check valve (1) into the hydraulic system (P to A). Pressure in port A acts via pilot line (3) on the pilot control spool (4). At the same time, pressure in port P passes via orifices (5) and (7) to the spring loaded side of the main spool (6) and poppet (8) in the pilot valve (2). As soon as the set cut-off pressure in the hydraulic system is reached, the poppet (8) lifts off against spring (9). Pressure fluid now flows via orifices (5) and (7) into spring chamber (11). From here, the fluid is returned to tank either internally via control line in valve type DA..30B/... or externally via control line in valve type DA..30B/..Y... Due to orifices (5) and (7), a pressure drop is now present at the main spool (6). The main spool (6) now lifts off its seat and opens the connection from P to T. The check valve (1) now closes the connection from A to P. The poppet (8) is now held open by the system pressure via pilot spool (4).

Diverting pump flow from P to T or P to A.

The area of the pilot spool (4) is 17% greater than effective area of the poppet(8). The effective force on the pilot spool (4) is, therefore, 17% greater than the effective force on the poppet (8). when the actuator pressure falls in relation to the cut-off pressure by a valve which corresponds to the switching pressure differential, spring (9) pushes poppet(8) on to its seat. Pressure is then built up on the spring loaded side of the main spool(6). In conjunction with spring (10), this closes the main spool(6) and isolates the connection from P to T. the pump flow passes once more via the check valve (1) into the hydraulic system(P to A).

Pressure shut-off valve type DAW

The function of this valve is principally the same as the DA valve. A solenoid actuated directional valve(12) can, however switch the set cut-off pressure which is under the pilot valve (2) either from P to T or from P to A.

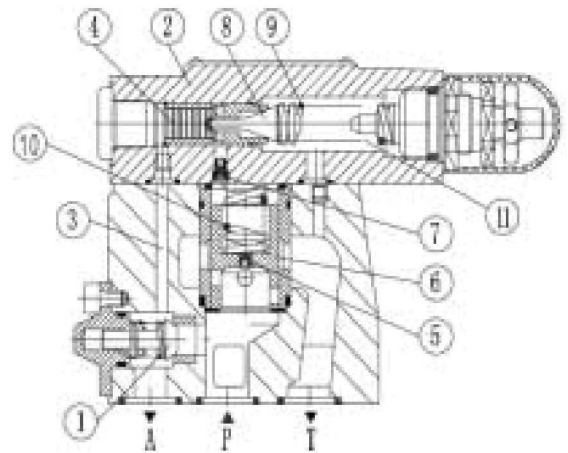

DA10...-30B/

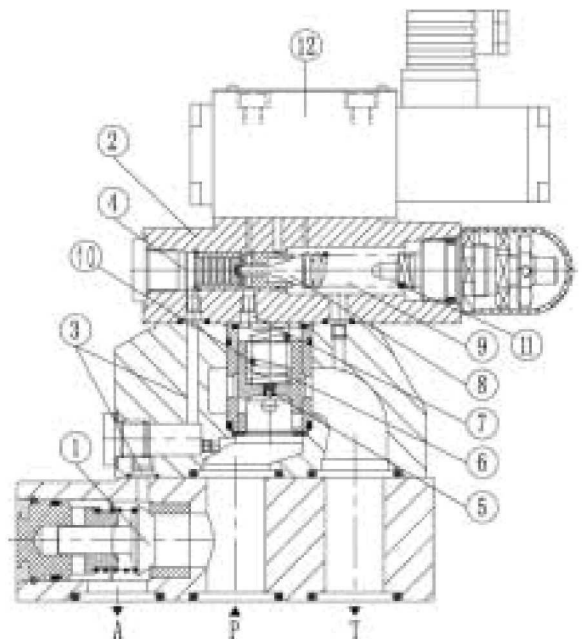

DAW20,30...-30B/

symbols

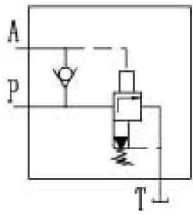

DA...-30B/...

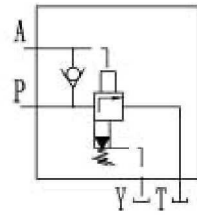

DA...-30B/...Y...

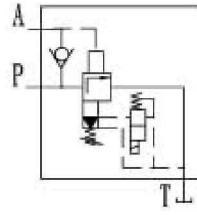

DAW...-30B/...

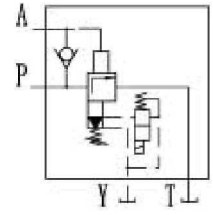

DAW...-30B/...Y...

Circuit examples

Hydraulic system with accumulator

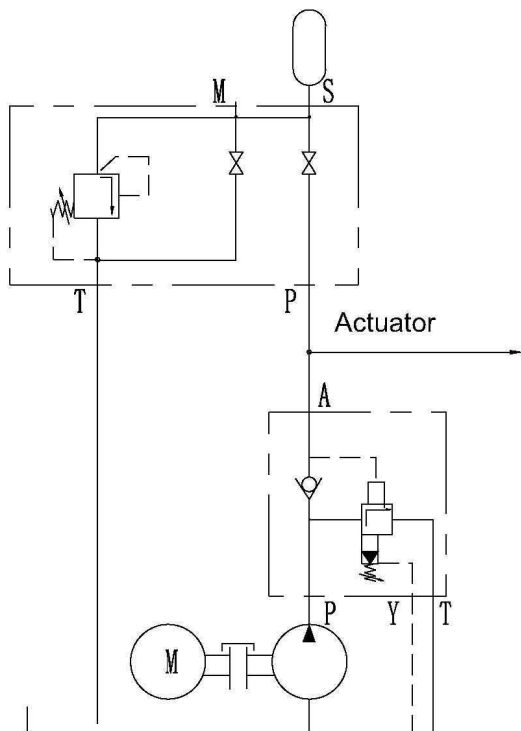

Application guidelines:

The connection between the DA valve and the hydraulic accumulator should be as short as possible and with a low pressure drop!

Hydraulic system with high and low pressure pumps

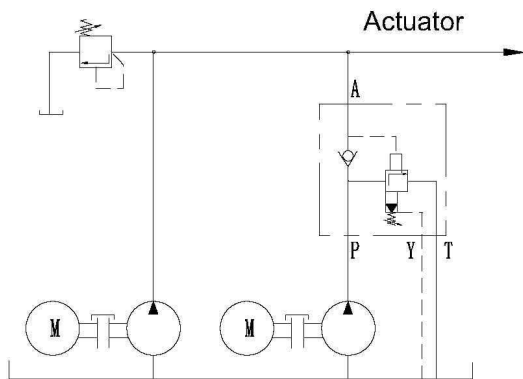

Characteristic curves (measured at $v = 41 \text{ mm}^2/\text{s}$ and $t = 50^\circ \text{ C}$)

By-pass pressure in relation to the pump flow q_{vp} P (P → T)

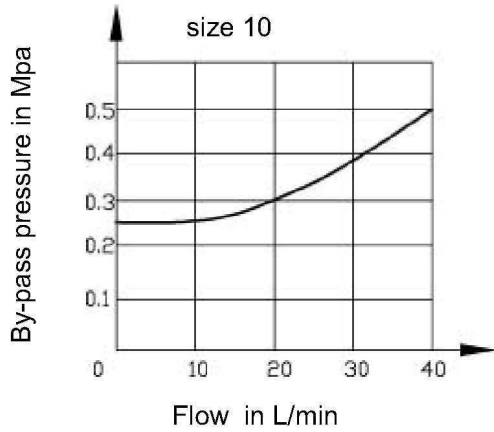

Switching pressure differential in relation to the cut-off pressure (P → A)

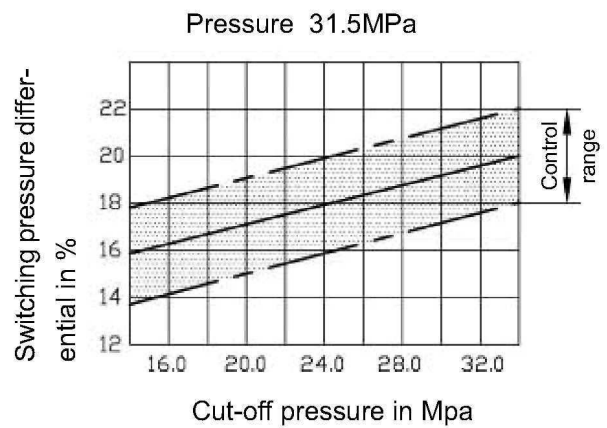
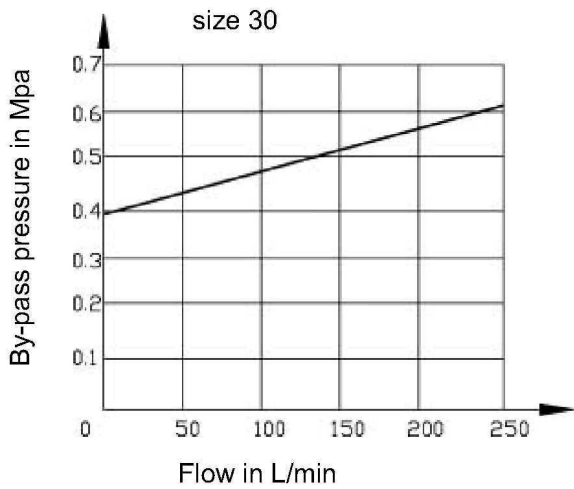
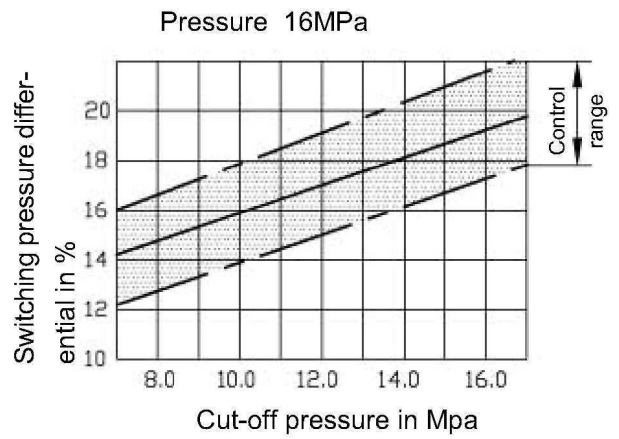
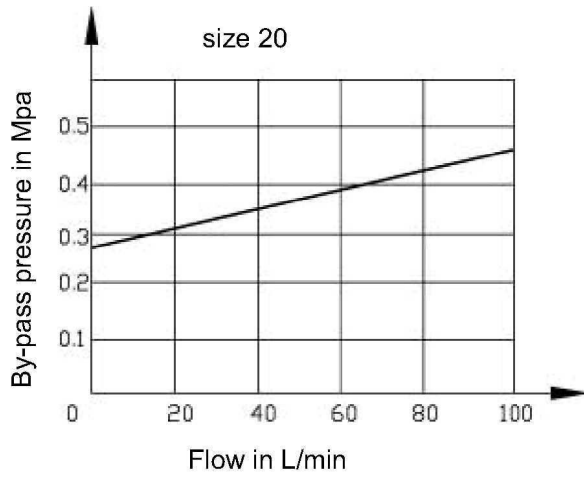
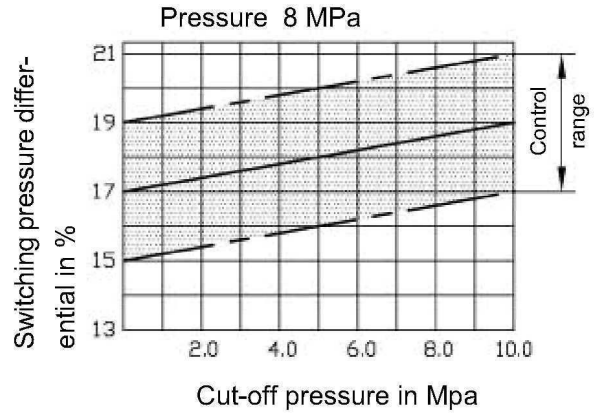

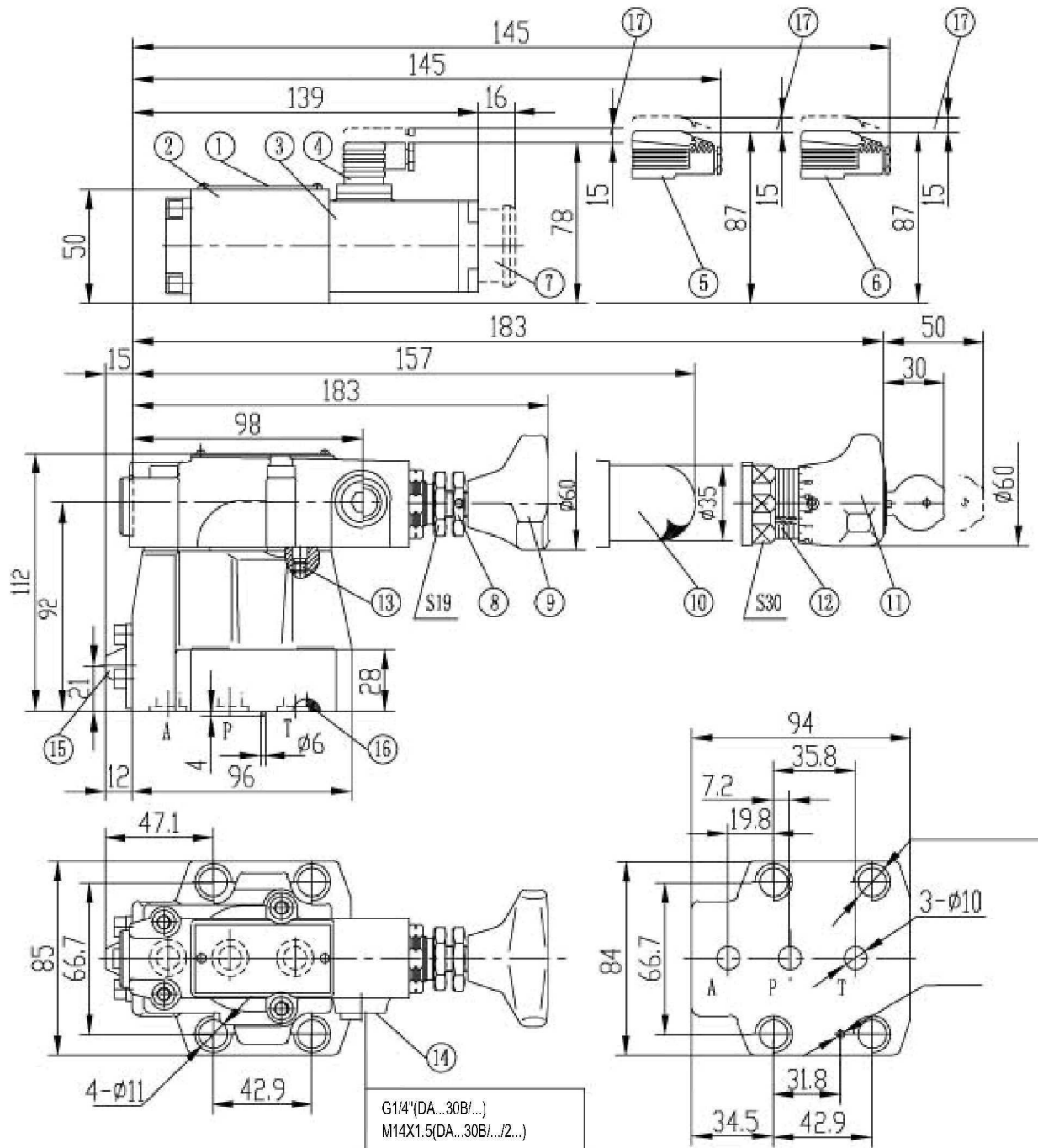

1. Nameplate
2. Directional valves, type WE5
3. Solenoid
4. Plug-in connector Z4
5. Large plug-in connector Z5
6. Large plug-in connector with light Z5L
7. Hand override, optional
8. Locknut(only apply to up to 31.5 Mpa)
9. Adjustment element 1
10. Adjustment element 2
11. Adjustment element 3

12. Repeat adjusting scale
13. Locating pin
14. Port Y for external pilot oil drain
15. Integrated check valve
16. O-ring 27.3X2.4
17. Space required to remove key fixing screw :

Subplate for: see page 151

G467/1 (G3/8") 12 (M18 × 1.5)

G468/1 (G1/2") 12 (M22 × 1.5)



Required surface finish of mating piece

DA/DAW Unit dimensions, size 20,30 (30 series):

(Dimensions in mm)

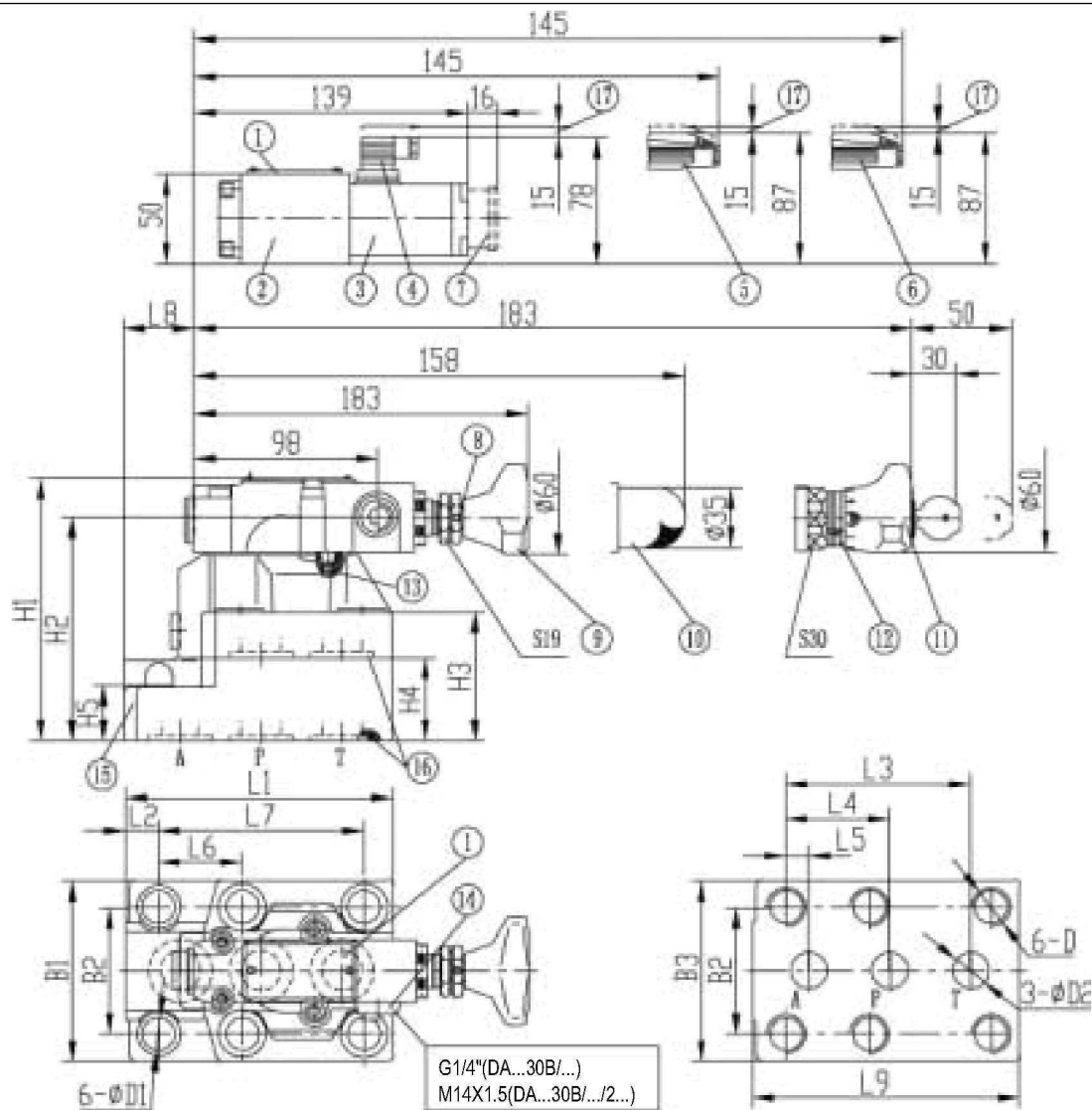

- | | | |
|---|---|-----------------|
| 1. Name plate | 13. Locating pin | 4-M16X100-10.9 |
| 2. Directional valves, type WE6 | 14. Port Y for external pilot oil drain | 2-M16X60-10.9 |
| 3. Solenoid | 15. Integrated check valve | (GB/T70.1-2000) |
| 4. Plug-in connector Z4 | 16. O-ring 27.3X2.4 | 4-M18X120-10.9 |
| 5. Large plug-in connector Z5 | DA/DAW20...30B/...:28.17X3.53 | |
| 6. Large plug-in connector with light Z5L | DA/DAW30...30B/...:34.52X3.53 | |
| 7. Hand override, optional | 17. Space required to remove key | |
| 8. Lock nut(only apply to up to 31.5MPa) | | |
| 9. Adjustment element 1 | DA/DAW20 DA/DAW30 | |
| 10. Adjustment element 2 | | |
| 11. Adjustment element 3 | | |
| 12. Repeat adjusting scale | | |

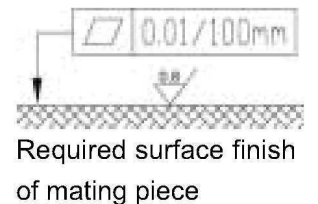

Size	L1	L2	L3	L4	L5	L6	L7	L8	L9	B1	B2
20	154	25	101.6	57.1	12.7	46	112.7	49	156	101	69.9
30	199	42	127	63.5	12.7	50.8	139.7	73	229	116	82.5
Size	B3	H1	H2	H3	H4	H5	ΦD1	ΦD2	D		
20	103	144	124	72	46	28	18	25	M16 depth 34		
30	118.5	165	145	93	67	45	20	32	M18 depth 37		

	DA/DAW20	DA/DAW30
Fixing screw	4-M16X100-10.9 2-M16X60-10.9 (GB/T70.1-2000)	4-M18X120-10.9 2-M18X80-10.9 (GB/T70.1-2000)
Subplate for see page 142	G469/1 (G3/4") G469/02 (M27 × 2) G470/1 (G1") G470/02 (M33 × 2)	G471/1 (G11/4") G471/02 (M42 × 2) G472/1 (G11/2") G472/02 (M48 × 2)

NOTICE

1. The fluid must be filtered. Minimum filter fineness is 20 μm .
2. The tank must be sealing up and an air filter must be installed on air entrance.
3. Products without subplate when leaving factory, if need them, please ording specially.
4. Vavle fixing screws must be high intensity level (class 10.9). Please select and use them according to the parameter listed in the sample book.
5. Roughness of surface linked with the valve is required to $0.8 \sqrt{R}$.
6. Surface finish of mating piece is required to 0.01/100mm.