



**Pressure sequence valve pilot operated,  
type DZ...30B/**

RE 26390/12.2004

Size 10,20,30

up to 21MPa

up to 450L/min

Replaces:  
RE26390/05.2001

**Features:**

- Suitable for use as a relief, sequence and bypass valve
- For subplate mounting
- For manifold block mounting
- 4 adjustment elements:
  - Rotary knob
  - Sleeve with hexagon and protective cap
  - Lockable rotary knob with scale
  - Rotary knob with scale
- 4 pressure ratings
- Check valve, optional

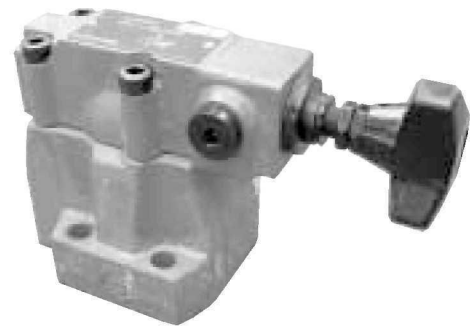

**Functional, section**

Pressure valves type DZ are pilot operated pressure sequence valves. They are used for pressure dependent sequence switching of a second circuit.

The pressure sequence valves basically consist of main valve (1) with main spool (6) and pilot valve (2) with pressure adjustment element and check valve (11), optional.

The valve function varies according to pilot oil drain configuration:

**Type DZ...-30B/210.**

The pressure in port A acts on the pilot spool (6) in the pilot valve (2) via the control line (4). At the same time it acts on the spring loaded side of the main spool (6) via orifice (8). When the pressure exceeds the value set at spring (7), the pilot piston (3) is moved against the spring (7). The signal is obtained internally from port A via control line (4). The fluid on the spring loaded side of the main spool (6) now flows to port B via orifice (9), control land (14) and lines (10). There is now a pressure drop at main spool (6), the connection from port A to port B is open maintaining the pressure set at spring (7). The leakage oil at pilot piston (3) is led to port B internally via line (10). An optional check valve (11) can be fitted for free return flow from port B to A.

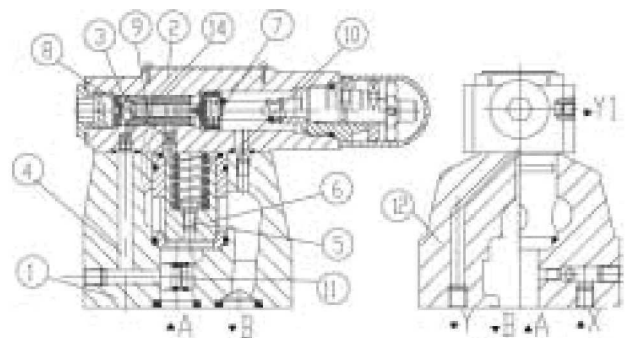

Type DZ...30B/210

**Type DZ...-30B/210X**

The function of this valve is principally the same as for valve DZ...30B/210. However, on pressure sequence valve type DZ...30B/...X.. the signal is given externally by means of port X.

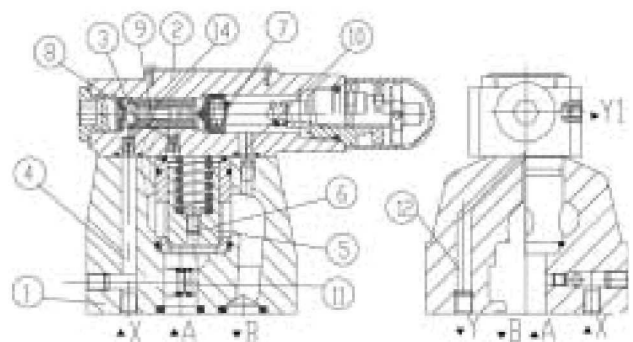

Type DZ...30B/210X

Type DZ...30B/210Y..

The function of this valve is principally the same as for valve type DZ...30B/....However, for type DZ...30B/...Y.. leakage at pilot piston (3) must be drained to tank.

Type DZ...30B/....XY...

Pressure in port X acts on the pilot piston (3) in the pilot valve (2) via control line (4). At the same time pressure in port A acts on the spring loaded side of the main spool (6) via orifice (5). When the pressure in port X exceeds the value set at the spring (7), the pilot piston (3) is moved against the spring (7). When pilot piston (3) is moved against spring (7), fluid can pass from the spring loaded side of the main spool (6) into the spring chamber of the pilot valve (2) via orifice (9) and line (16) and pressure breaks down on the spring loaded side of the main spool (6).

The fluid can, therefore, pass from port A to B with minimum loss of pressure. The pilot oil in spring chamber (17) should be drained to tank via line(14) or port Y.

Optional check valve (11) can be fitted for free return flow from port B to A.

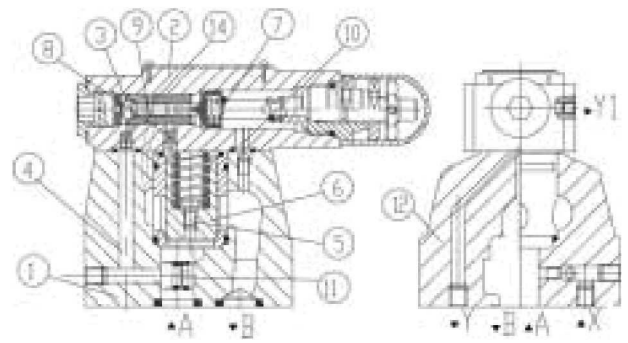

Type DZ...30B/210Y

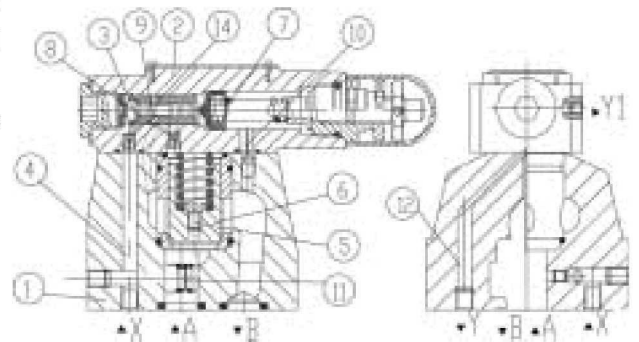

Type DZ...30B/210X Y

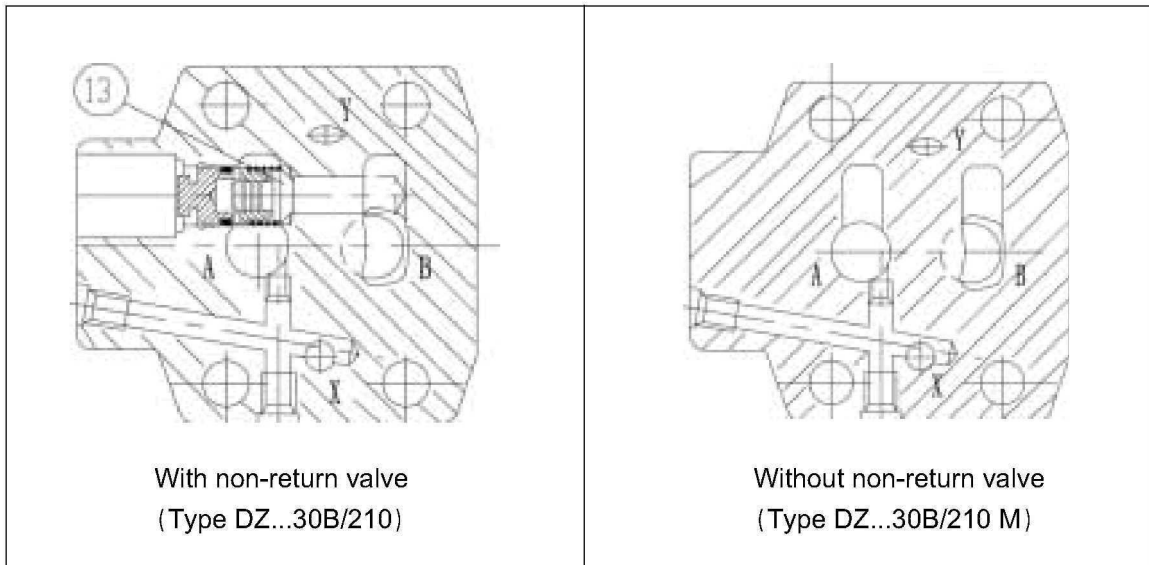

## Symbols of control oil

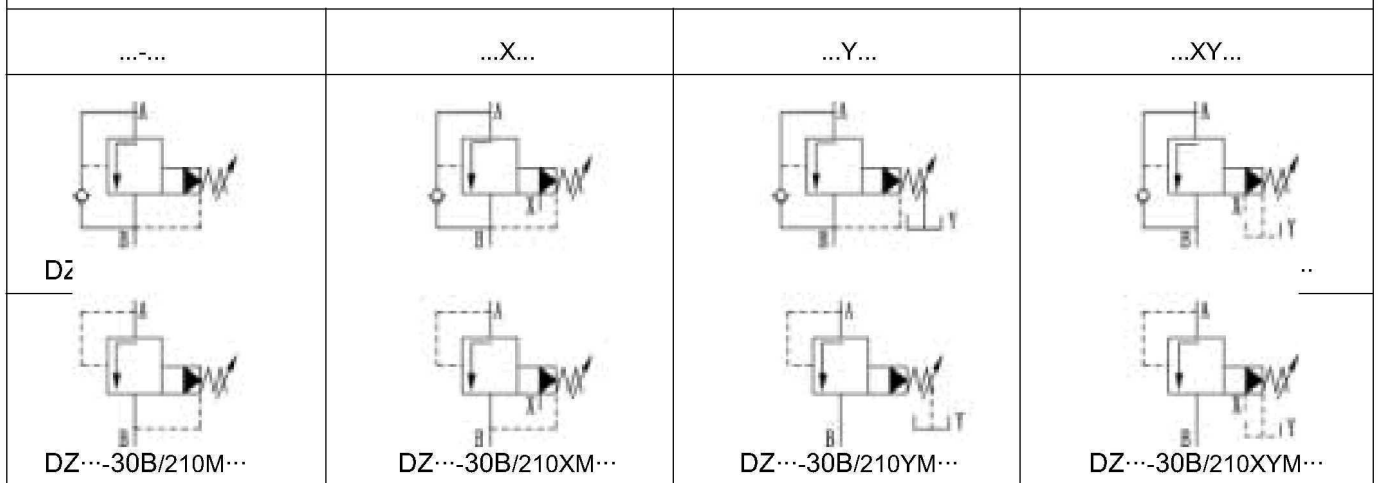

## Ordering details

DZ					-	30	/	210	/	/				
----	--	--	--	--	---	----	---	-----	---	---	--	--	--	--

Pilot operated valve =No code  
 Pilot operated valve without main spool insert (do not state nominal size) = C  
 Pilot operated valve with main spool insert (state valve size 30) = C

Nominal size 10 = 10  
 Nominal size 25 = 20  
 Nominal size 32 = 30

### Adjustment element

Rotary knob = 1  
 Sleeve with hexagon and protective cap = 2  
 Lockable rotary knob with scale = 3

Series 30 to 39 =30  
 (30 to 39: unchanged installation and connection dimensions)

Further deatils in clear text

No code. = mineral oils  
 V = phosphate ester

No code= pilot port, G1/4"  
 2= pilot port, M14X1.5

No code = With check valve  
 M = Without check valvePilot oil supply

No code = Poilt fluid feed internal ,return internal  
 X= Poilt fluid feed external,return internal  
 Y= Poilt fluid feed internal,return external  
 XY= Poilt fluid feed external,return external

210 = Max. settable pressure up to 21MPa

## Technical data

Size	10	20	30
Flow (L/min)	150	300	450
Operating pressure (MPa)	up to 31.5, for A, B, X		
Backpressure, port Y (MPa)	up to 31.5		
Adjust pressure (MPa)	0.3 (in related to Q) ~21		
Fluid	Mineral oil (for NBR seal),or phosphate ester (for FPM seal)		
Viscosity range (mm <sup>2</sup> /s)	10~800		
Fluid temperature range (°C)	-30~+80		

**Characteristic curves** (measured at  $v = 41 \text{ mm}^2/\text{s}$  and  $t = 50$ )

The characteristic curves are valid for outlet pressure  $P_b = 0$  for the complete flow range

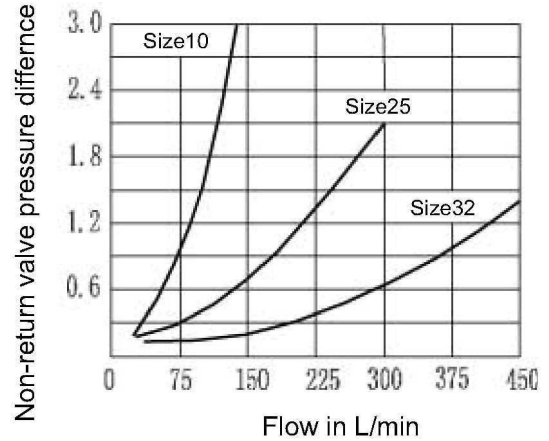
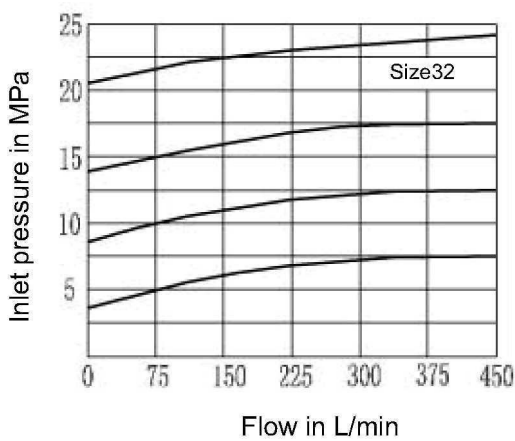
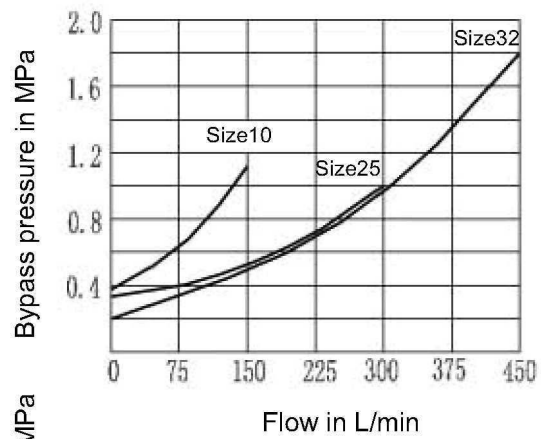
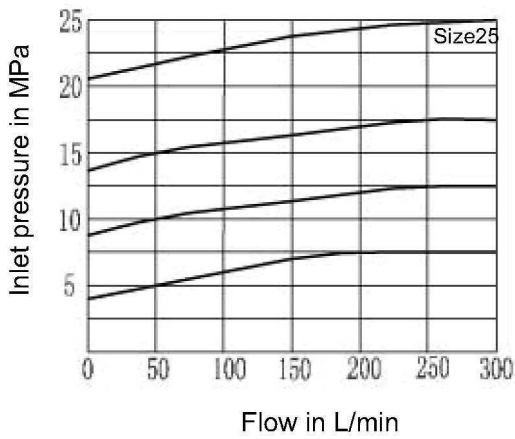
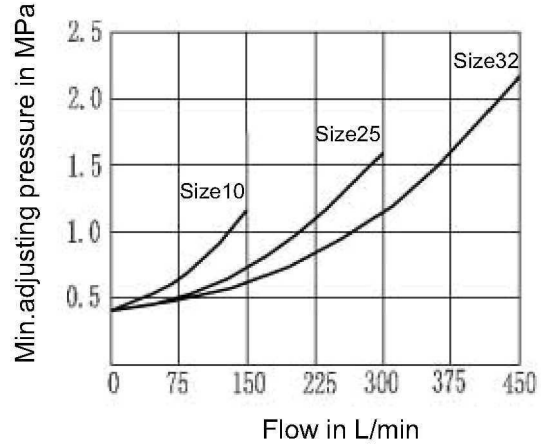
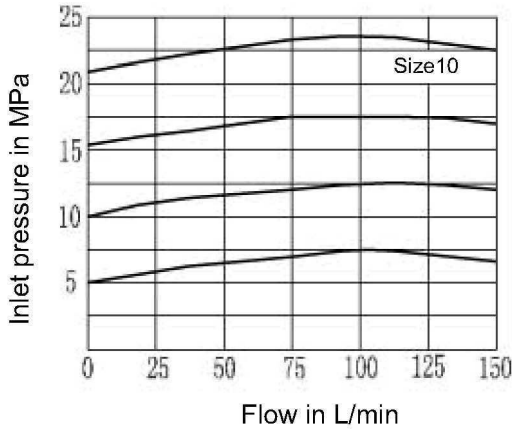

**Unit dimensions: pilot operated valve**

**(Dimensions in mm)**

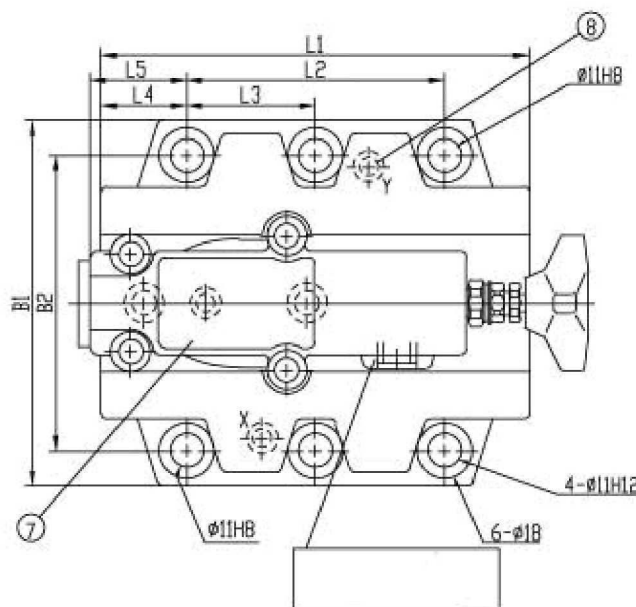
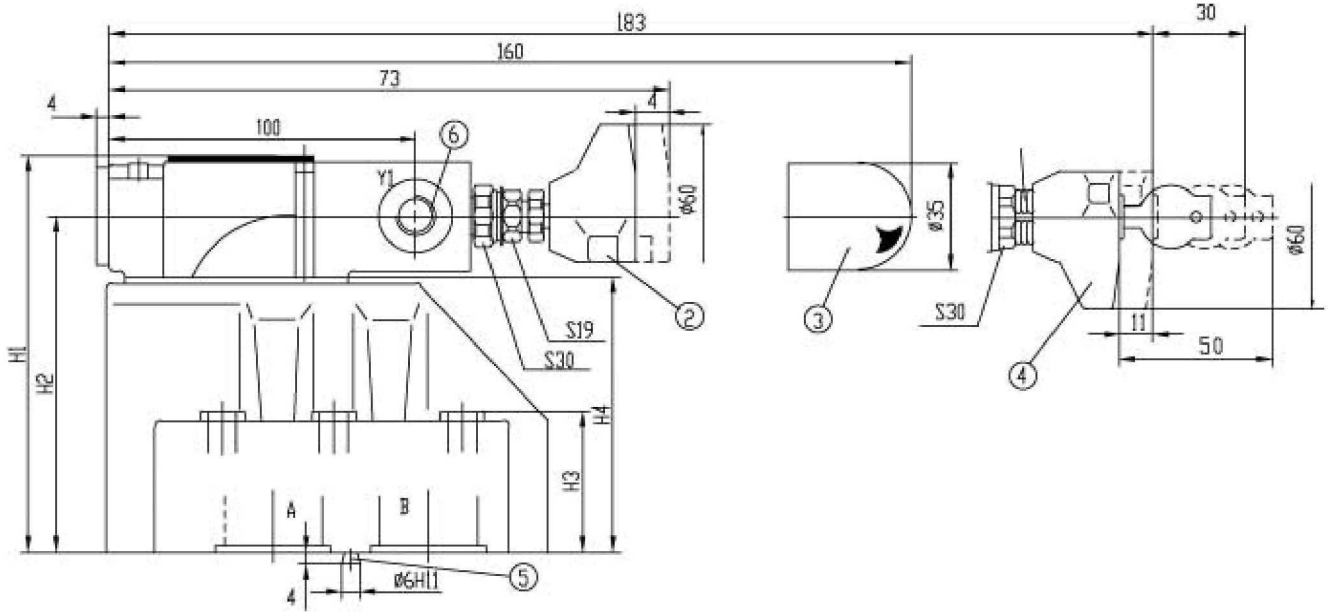

1. Repeat adjusting scale
2. Adjustment element 1
3. Adjustment element 2
4. Adjustment element 3
5. Locating pin
6. Port Y1 (G 1/4; 12) for external pilot oil drain when used as a bypass valve, unloading of spring chamber when used as sequence valve
7. Nameplate
8. Port Y for external point oil drain when used as a unloading valve

**Subplates:** see page 150  
 G412/01 G412/02  
 G413/01 G413/02  
 G414/01 G414/02  
 G415/01 G415/02  
 G460/01 G460/02  
 G461/01 G461/02

Size	B1	B2	H1	H2	H3	H4	L1	L2	L3	L4	L5	O-ring		Fixing screws (GB/T70.1-2000)	Weight (Kg)
												Port X,Y	Port A,B		
10	85	66.7	112	92	28	72	90	42.9	-	35.5	34.5	9.25 × 1.78	17.12 × 2.62	4-M10 × 50	3.6
20	102	79.4	122	102	38	82	112	60.3	-	33.5	36.5		28.17 × 3.53	4-M10 × 60	5.5
30	120	96.8	130	110	46	90	140	84.2	42.1	28	31.3		34.52 × 3.53	6-M10 × 70	8.2

**Unit dimensions: pilot operated valve**

**(Dimensions in mm)**

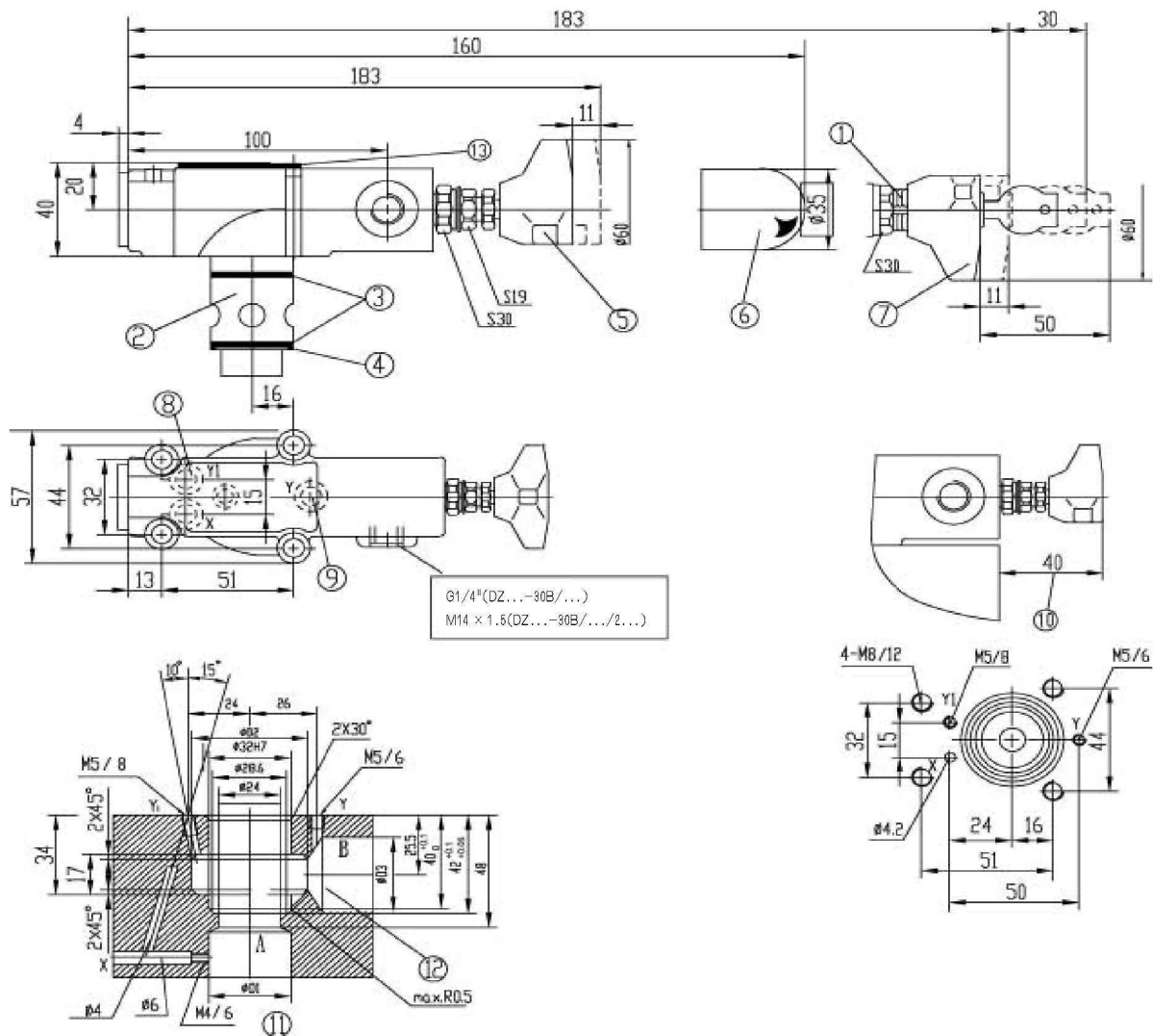

1. Repeat adjusting scale
2. Main spool insert
3. O-ring 27.3 x 2.4
4. Back-up ring 32/28.4X0.8
5. Adjustment element 1
6. Adjustment element 2
7. Adjustment element 3
8. Port Y1  
pilot oil drain when used as reduce or sequence valve
9. Port Y  
pilot oil drain when used as bypass valve; unloading of spring chamber when used as sequence valve
10. Min.distance when use the adjustment element"1"or"3"
11. This drilling is not required when used as unloading valve
12. Hole D3 can meet hole D2 at any location.  
Care has to be taken that connection hole X and the fixing hole are not damaged.
13. Nameplate

Size	φ D1	φ D2	φ D3	Fixing screws (GB/T70.1-2000)	Weight (Kg)
10	10	40	10	4-M8 × 40-10.9	1.4
20	25	40	25		
30	32	45	32		

## NOTICE

1. The fluid must be filtered. Minimum filter fineness is 20  $\mu\text{m}$ .
2. The tank must be sealing up and an air filter must be installed on air entrance.
3. Products without subplate when leaving factory, if need them, please ording specially.
4. Vavle fixing screws must be high intensity level (class 10.9). Please select and use them according to the parameter listed in the sample book.
5. Roughness of surface linked with the valve is required to  $0.8 \sqrt{R}$ .
6. Surface finish of mating piece is required to 0.01/100mm.