

**Features**

- For subplate mounting
- For pipe installation
- As vertical stacking element to porting pattern DIN 24 340 J4
- In horizontal stacking assemblies
- 5 pressure stages
- 4 adjustment elements:
  - Spindle with internal hexagon, with or without protective cap (protective cap can be sealed)
  - Spindle with internal hexagon and scale, with or without protective cap
  - Rotary knob with scale
  - Lockable rotary knob with scale
- Plug-in connector with circuitry (indicator lamp)(separate order)

**Function, section, symbol**

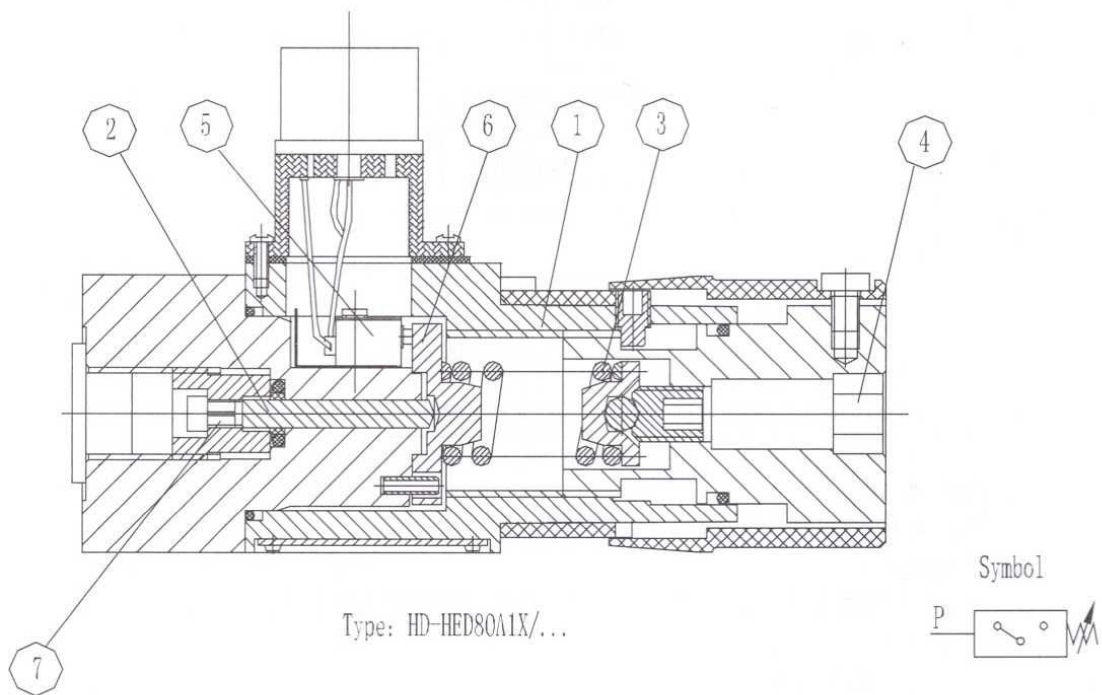

Hydro-electric pressure switches type HD -HED 8 are piston type pressure switches .

They basically consist of the housing (1), cartridge with piston (2), compression spring (3), adjustment element (4) and micro-switch(5).If the pressure to be monitored is below the set value then the microswitch(5) is actuated. The pressure to be monitored is applied to the piston (2) via orifice (7). The piston (2) supports itself on the spring plate (6) and acts against the infinitely adjustable force of the compression spring (3). The spring plate (6) transfers the movement of the piston (2) to the micro-switch (5) and releases the same on reaching the set pressure. Through this, the electrical circuit is either switched on or off according to the circuit design. The mechanical stop of the spring plate (6) protects the micro-switch (5), in the case of sudden pressure loss, from mechanical destruction and prevents the compression spring (3) from blocking if an over-pressure occurs.

## Note

### Note:

To increase the service life the pressure switch should be mounted vibration- proof,  
be protected from hydraulic pressure shocks.

Orifice (7) which is fitted as standard, can be replaced and matched according to the required degree of damping required.

## Ordering details

IID	IED8		1X	K14			*
Huade hydraulic = HD							Further details in clear text
Piston type pressure switch							
Subplate mounting	=OP						
Pipe installation	=OA						
Vertical stacking systems	=OH						
Series 10 to 19 (10 to 19: unchanged installation and connection dimensions)	= 1X						
Max. settable pressure 5MPa	=50						
Max. settable pressure 10MPa	=100						
Max. settable pressure 20MPa	=200						
Max. settable pressure 35MPa	=350						
Max. settable pressure 63MPa	=630						
Electrical connection type Single connection; with component plug DIN 43 650-AM2, without plug-in connector	=K14						
Spindle (without scale)	= No code						
Spindle (without scale) with protective cap	= S						
Spindle with scale	= A						
Spindle with scale and protective cap	= AS						
Lockable rotary knob with scale	= KS 3)						
Rotary knob with scale	= KW						
British	= No Code						
Metric	= /2						
NBR seals	= No code						
FKM seals	= V						
(other seals on request)							

## Technical data (for applications outside these parameters, please consult us!)

### General

Weight - Pressure switch	(kg)	0.8
		0.8 (NS 6, plate height 40.5 mm)
- Sandwich plate for vertical stacking assemblies	(kg)	3 (NS 6, plate height 120 mm)
		2 (NS 10)

### Hydraulic

Pressure fluid		Mineral oil; Fast bio-degradable hydraulic fluids
Pressure fluid temperature range	(°C)	-30 ~ +50 (for NBR seals) -20 ~ +50 (for FPM seals)
Condition temperature range	(°C)	-30 ~ +50 (for NBR seals) -20 ~ +50 (for FPM seals)
Viscosity range	(mm <sup>2</sup> /s)	10 ~ 800
Degree of contamination		Maximum permissible degree of contamination of the pressure fluid is to NAS 1638 class 9. We, therefore recommend a filter with a minimum retention rate of $\beta_{10} \geq 75_e$ .
Switching accuracy (repeatability)		< ± 1 % of settable range
Permissible switching frequency	(1/h)	4800

### Pressure setting range

Pressure stage (Max. settable pressure) in MPa	Max. operating pressure in MPa	Pressure setting range in MPa
5	35	0.2 to 5
10	35	0.4 to 10
20	35	0.5 to 20
35	50	0.8 to 35
63	63	3 to 63

### Electrical technical data

Electrical connection		plug-in connector to DIN 43 650, form A, 3-pin + PE
Max. connection cross sectional area	mm <sup>2</sup>	1.5
Max. contact load	-AC	250V; 5A
	-DC	50V/1A; 125V/0.03A; 250V/0.02A
Protection to DIN 40 050		IP65



# Switching pressure differential

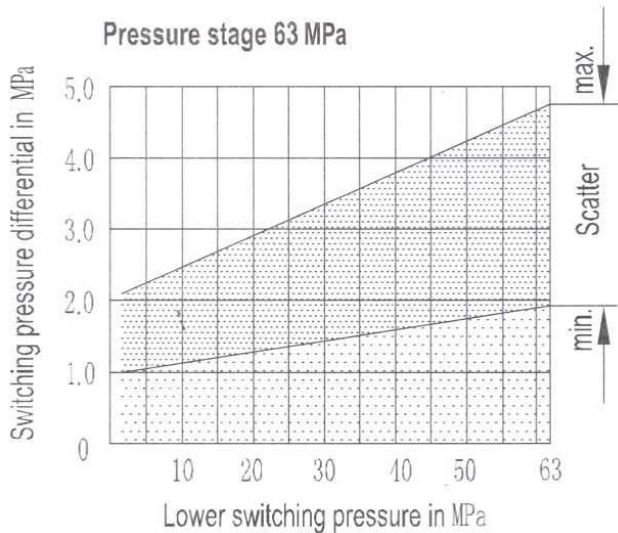
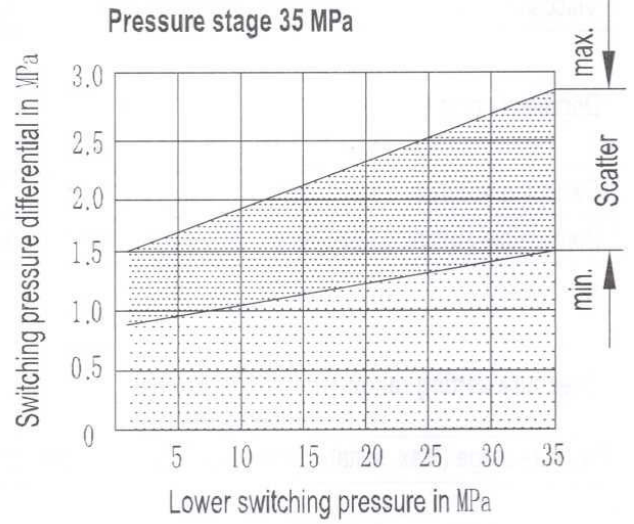
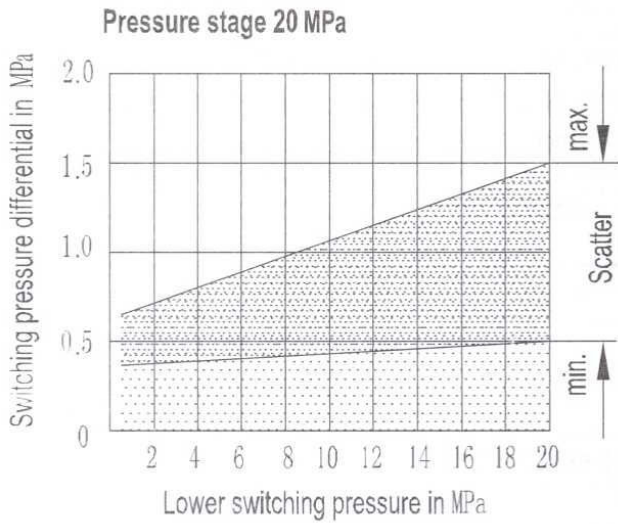
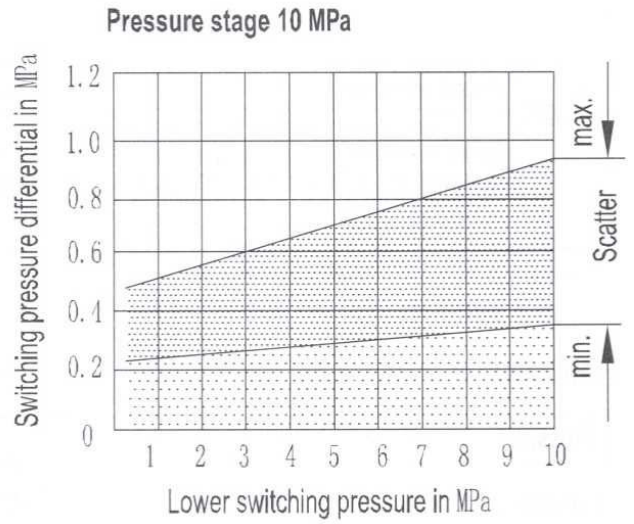
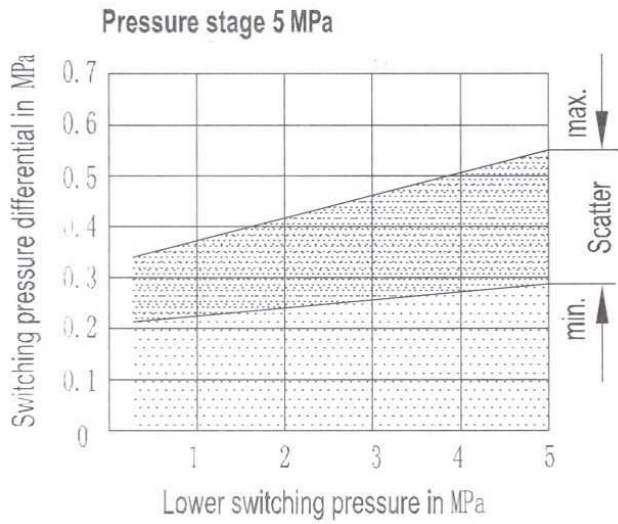

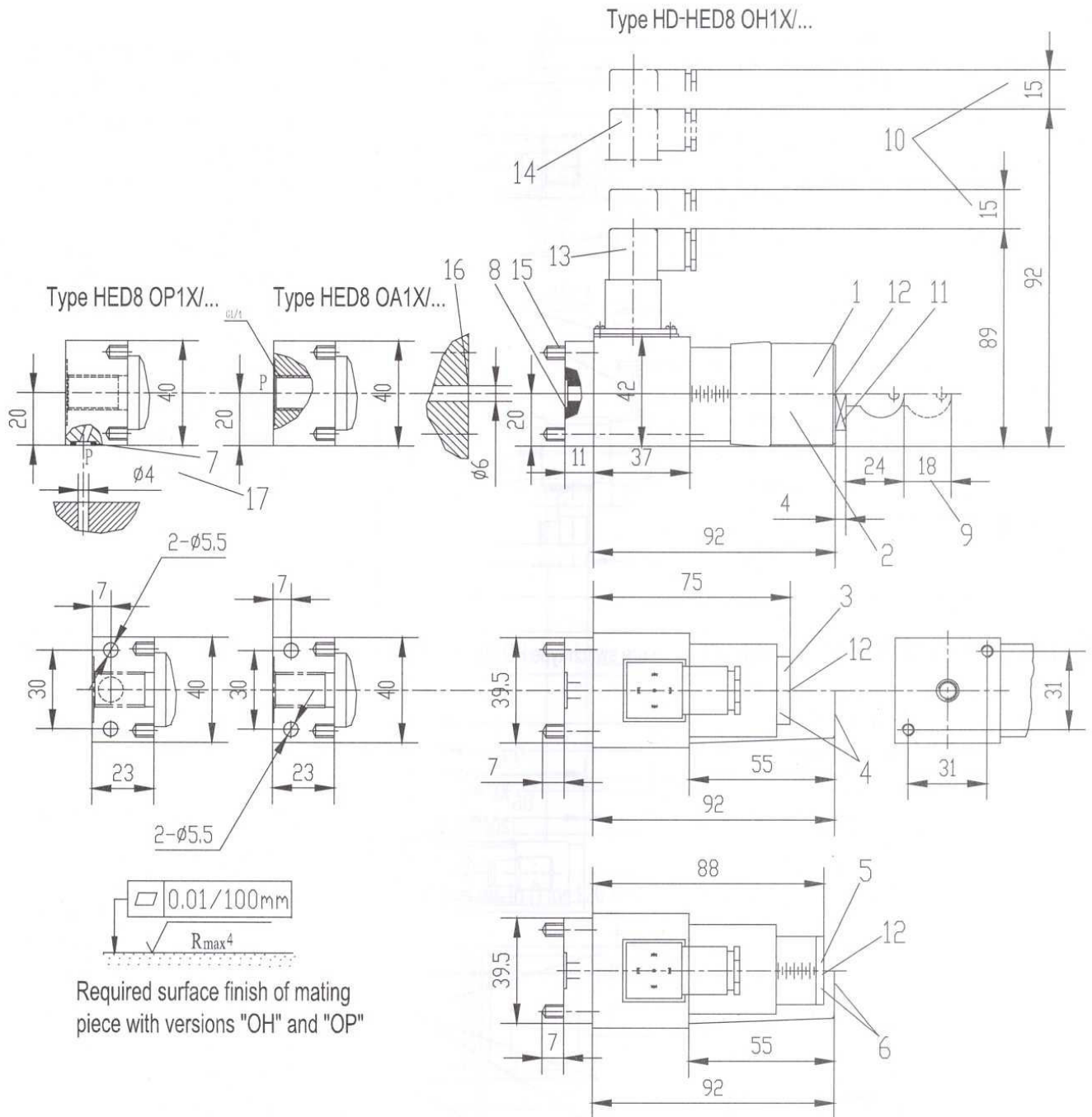

- 1 Adjustment element "KW"
- 2 Adjustment element "KS"
- 3 Adjustment element "-"
- 4 Adjustment element "S"
- 5 Adjustment element "A"
- 6 Adjustment element "AS"
- 7 R-ring 5.28 x 1.78 x 1.78
- 8 O-ring 11 x 1.5  
(R-ring 11.18 x 1.6 x 1.78) 2)
- 9 Space required to remove the key
- 10 Space required to remove the plug-in connector
- 11 Hexagon A/F 27 (adjustment element "KS")
- 12 Hex. socket A/F 10
- 13 Plug-in connector without circuitry to DIN 43 650 1)

- 14 Plug.in connector with circuitry to DIN 43 650 1)
- 15 2 off fixing screws M5 x 12 (M5 x 16) 2)  
DIN 912-10.9, tightening torque  $MA = 8.9 \text{ Nm}$   
(included within the scope of supply).
- 16 Maximum diameter of the mounting surface  
of the mating piece (type HED 8 OH1X/?
- 17 Maximum diameter of the mounting surface  
of the mating piece (type HED 8 OP1X/?
- Valve fixing screws** (types HED 8 OA and HED 8  
OP) M5 x 50  
DIN 912-10.9, tightening torque  $MA = 8.9 \text{ Nm}$ , must  
be ordered separately.
- 1) Must be ordered separately, see page 2.
- 2) Details for ( ) only for pressure stage 63 MPa!

**Installation guidelines:** for applying the pressure switch HED8 in stacking assemblies **NS 6** (Dimensions in mm)

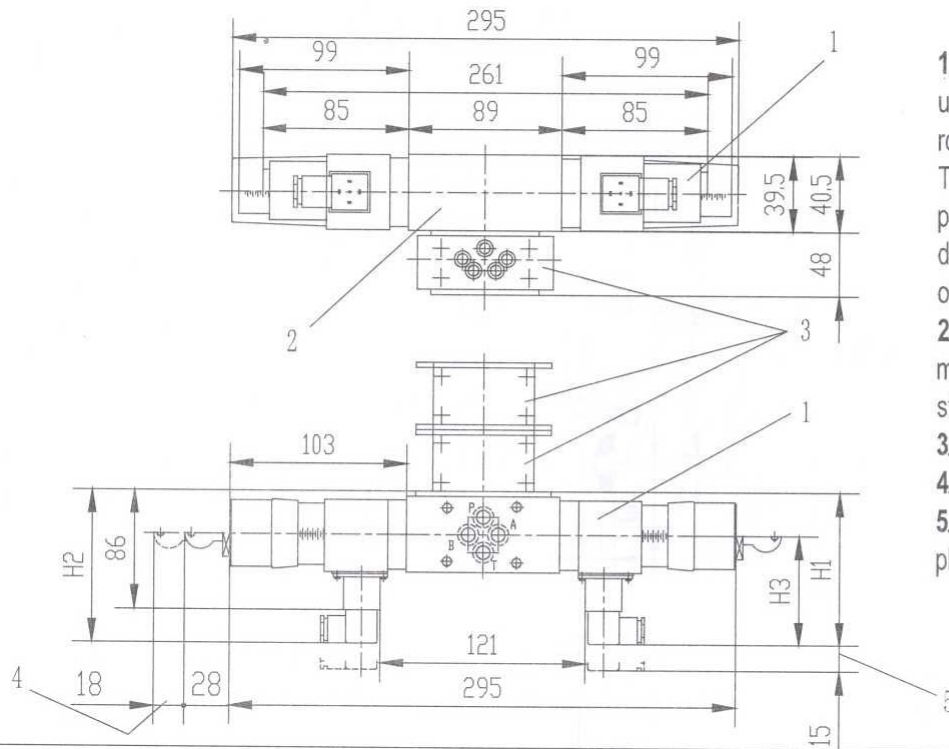

1. Pressure switch HED 8 OH... for use in stacking assemblies (can be rotated 4 x 90° for mounting)  
The mounting possibilities of the pressure switch depends on the design of the adjacent stacking plates!
2. Sandwich plate type HSZ 06 for mounting the pressure switch as a stacking element
3. Stacking elements
4. Space required to remove the key
5. Space required to remove the plug-in connector

**Installation guidelines:** for applying the pressure switch type HD-HED8... in stacking assemblies **NS 10** (Dimensions in mm)

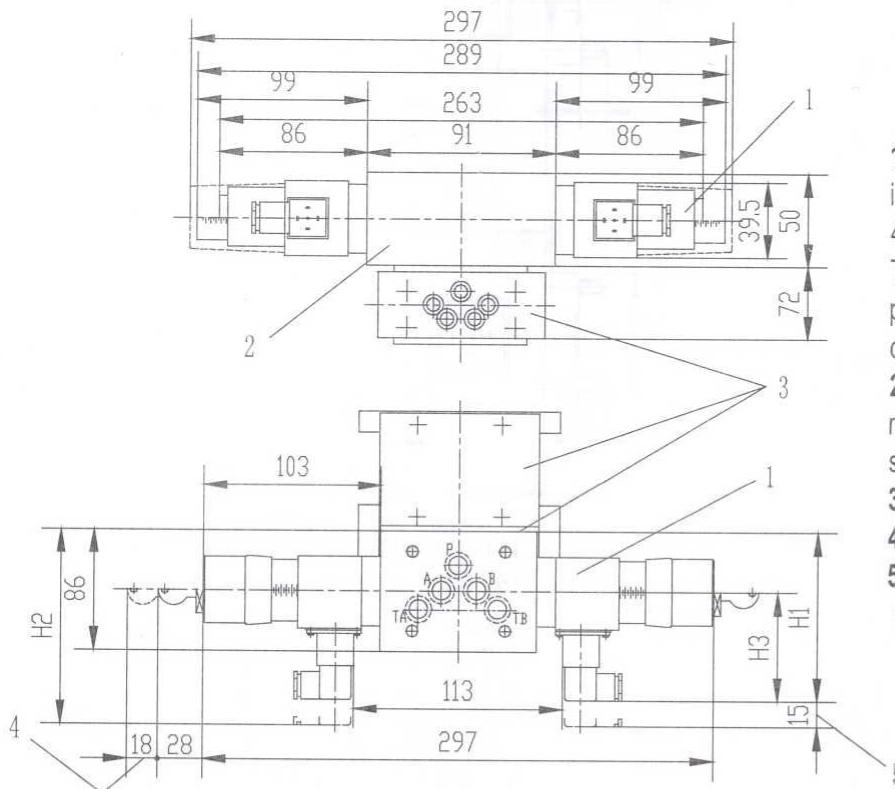

1. Pressure switch HED 8 OH... for use in stacking assemblies (can be rotated 4 x 90° for mounting)  
The mounting possibilities of the pressure switch depends on the design of the adjacent stacking plates!
2. Sandwich plate type HSZ 10 for mounting the pressure switch as a stacking element
3. Stacking elements
4. Space required to remove the key
5. Space required to remove the plug-in connector

		H1	H2	H3
Nom. size 6	Plug-in connector <b>without</b> circuitry	91	102	69
	Plug-in connector <b>with</b> circuitry	94	105	72
Nom. size 10	Plug-in connector <b>without</b> circuitry	104	112	69
	Plug-in connector <b>with</b> circuitry	107	115	72



**Sandwich plate Ns 6:** for applying the pressure switch type HD-HED8... as a vertical stacking element (up to 35MPa) (Dimensions in mm)

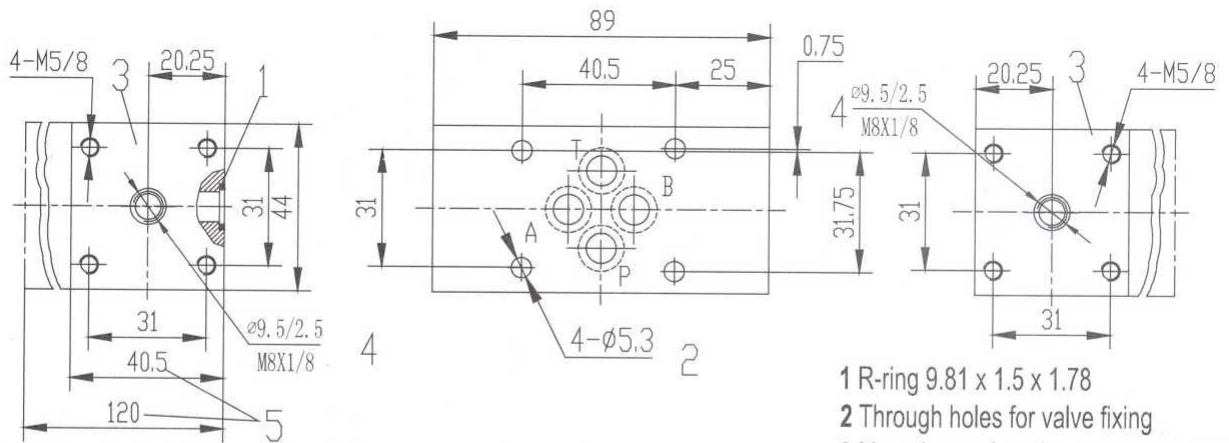

- 1 R-ring 9.81 x 1.5 x 1.78
  - 2 Through holes for valve fixing
  - 3 Mounting surface for pressure switch
  - 4 Measuring port, optional
  - 5 Plate height 40.5 mm or 120 mm, optional
- Sandwich plates must be ordered separately.**

HSZ	06	A	3X	00	*
-----	----	---	----	----	---

Sandwich plate	
Nominal size 6	= 6
Porting pattern to DIN 24 340, form A	= A
Version no. (see below)	= 6...
Series 30 to 39	<b>= 3X</b>
(30 to 39: unchanged installation and connection dimensions)	

Further details in clear text

**M** = NBR seals  
**V** = FKM seals  
 (other seals on request)

**Sandwich plate NS 6:** symbols, version no. (version no. in () for 120 mm plate height!)  
 ( 1 = component side, 2 = subplate side)

Pressure switch effective in channel?			
<b>Version no.</b>	608 (627)	609 (628)	601 (620)
Pressure switch effective in channel?			
<b>Version no.</b>	602 (621)	603 (622)	604 (623)
Pressure switch effective in channel?			
<b>Version no.</b>	605 (624)	606 (625)	607 (626)
Pressure switch effective in channel?			
<b>Version no.</b>	610 (629)	611 (630)	612 (631)

**Sandwich plate Ns 6:** for applying the pressure switch type HD-HED8... as a vertical stacking element (up to 35MPa) (Dimensions in mm)

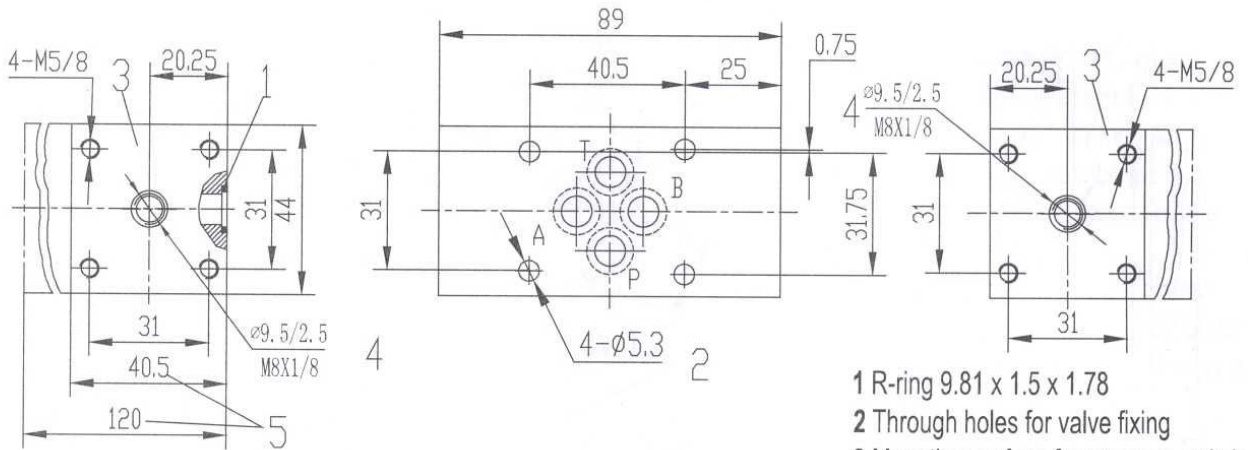

- 1 R-ring 9.81 x 1.5 x 1.78
  - 2 Through holes for valve fixing
  - 3 Mounting surface for pressure switch
  - 4 Measuring port, optional
  - 5 Plate height 40.5 mm or 120 mm, optional
- Sandwich plates must be ordered separately.**

HSZ 06 A 3X 00 \*

Sandwich plate	
Nominal size 6	= 6
Porting pattern to DIN 24 340, form A	= A
Version no. (see below)	= 6...
Series 30 to 39 (30 to 39: unchanged installation and connection dimensions)	= 3X

Further details in clear text

**M** = NBR seals  
**V** = FKM seals  
 (other seals on request)

**Sandwich plate NS 6:** symbols, version no. (version no. in () for 120 mm plate height!)  
 ( 1 = component side, 2 = subplate side)

Pressure switch effective in channel?			
<b>Version no.</b>	608 (627)	609 (628)	601 (620)
Pressure switch effective in channel?			
<b>Version no.</b>	602 (621)	603 (622)	604 (623)
Pressure switch effective in channel?			
<b>Version no.</b>	605 (624)	606 (625)	607 (626)
Pressure switch effective in channel?			
<b>Version no.</b>	610 (629)	611 (630)	612 (631)