

Normalde-Açık, İki-Yollu, İki-Konumlu, Poppet Tip Kartriç Solenoid Valf

LSV2-08-2 NOP

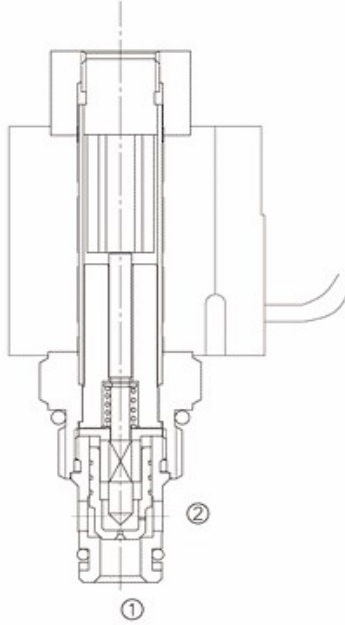

Normally-Open, Two-Way, Two-Position, Poppet Type Cartridge Solenoid Valve

OPERATION

When de-energized, the valve allows flow from ② to ①. Flow from ① to ② is severely restricted in this mode.

When energized, the valve's poppet closes on its seat, blocking flow from ② to ①. The cartridge will allow ① to ② flow after overcoming the solenoid force.

Operation of Manual Override Option: To override, push button in to activate. To return to normal valve function, release button.

FEATURES

- Continuous-duty solenoid.
- Hardened seat for long life .
- Optional coil voltages and terminations.
- Efficient wet-armature construction.
- Filter screen standard.
- Industry common cavity.
- Compact size.

ÖZELLİKLER

- Sürekli-çalışabilen bobin
- Uzun ömür için sertleştirilmiş yuva
- Seçmeli bobin voltajı vesınırlama
- Etkili ıslak-armatür konstrüksiyon
- Standart Filtreleme
- Endüriyel standartlarda kavite
- Kompakt boyut

SYMBOL

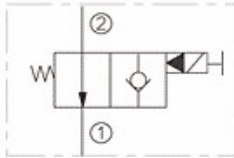

PRESSURE DROP VS. FLOW

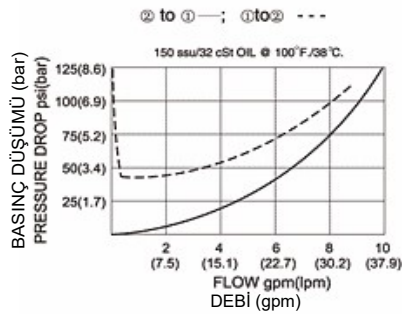

SPECIFICATIONS

Max. Operating Pressure : 300Bar

Flow : See PRESSURE DROP VS. FLOW graph.

Internal Leakage : 5 drops/minute max. at 300Bar .

Temperature : -30°F to +250°F (-35°C to +120°C)

Coil Rating : Continuous from 85% to 115% of nominal voltage.

Recommended Filtration: Critical Application-ISO 16/12
Non-Critical Application-ISO 19/15

Fluids : Mineral-based fluids.

For other fluid compatibility consult factory.

Cavity : 08-2, See page 264

Body Material : Anodized 6061T6 aluminum alloy rated at 207 Bar.
6061-T6,
Steel rated at 350 Bar.

Hidrosam Hidropar Hidrolik Pnömatik Elektrik San.Tic. Ltd

Alaaddinbey mah. 623 sok. Sam 1 plaza B blok No:2/d Nilüfer/BURSA TURKEY

Tel:+90224 441 8877 Fax:+90224 441 0333

info@hidrosam.com www.hidrosam.com

YERLEŞTİRME ÖLÇÜLERİ INSTALLATION DIMENSIONS

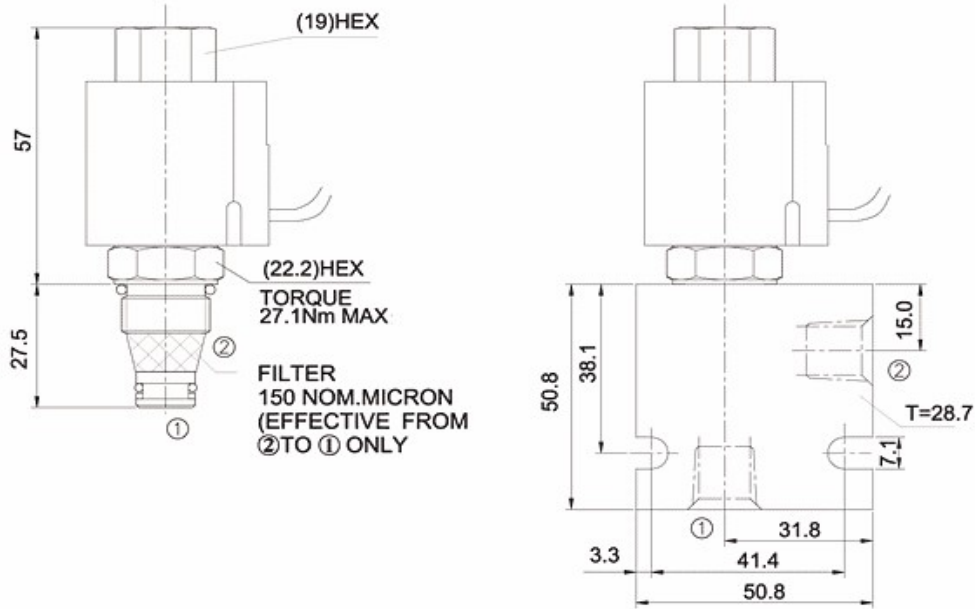

Unit=Millimeters

TO ORDER

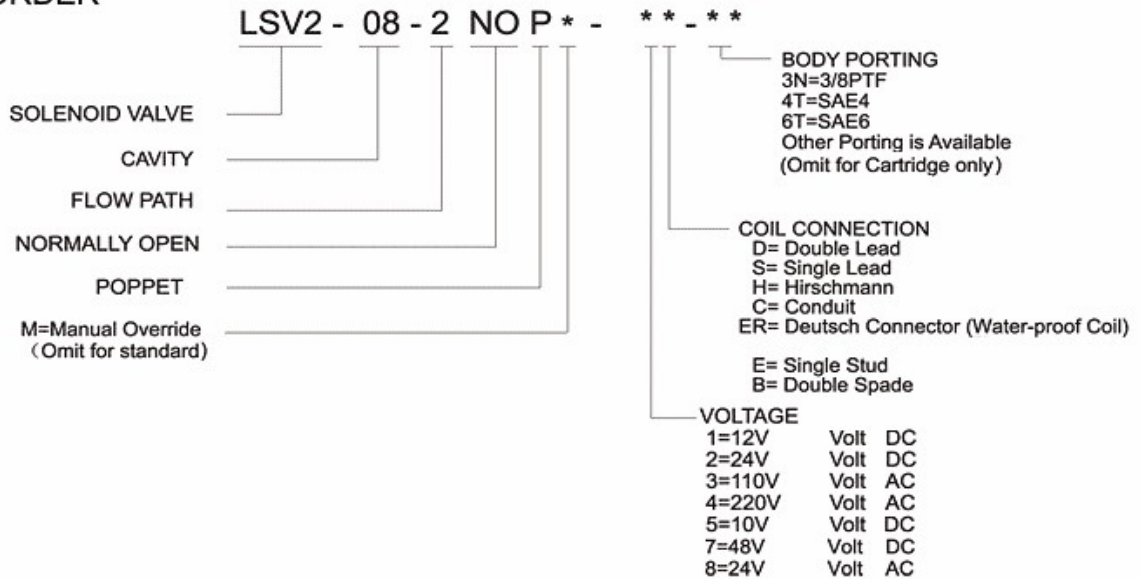

Hidrosam Hidropar Hidrolik Pnömatik Elektrik San.Tic. Ltd
Alaaddinbey mah. 623 sok. Sam 1 plaza B blok No:2/d Nilüfer/BURSA TURKEY
Tel:+90224 441 8877 Fax:+90224 441 0333

info@hidrosam.com www.hidrosam.com