

LSV2-10-2 NCP

Normalde-Kapalı,iki-Yollu,İki-Konumlu,
Pilot Uyarılı Kartriç Solenoid Valf
Normally-Closed, Two-Way, Two-
Position,Pilot-Operated Cartridge
Solenoid Valve

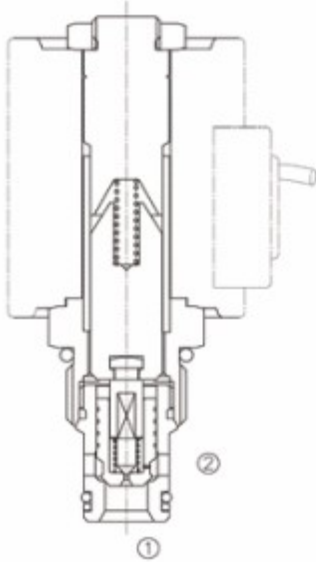

OPERATION

When de-energized, the valve acts as a check valve, allowing flow from ① to ②, while blocking flow from ② to ①.

When energized, the poppet lifts to open the ② to ① flow path.

Operation of Manual Override Option: To override, push button in, twist counterclockwise and release. In this position, valve will remain open in a detented condition.

To return to normal operation, push button in, twist clockwise and release. Override will be detented in this position.

FEATURES

- Continuous-duty solenoid.
- Hardened poppet and plunger for long life.
- Efficient wet-armature construction.
- Optional coil voltages and terminations.
- Filter screen standard.
- Industry common cavity.
- Compact size.

ÖZELLİKLER

- Sürekli-çalışabilen bobin
- Uzun ömür için sertleştirilmiş popet ve pompa
- Etkili ıslak-armatür konstrüksiyon
- Seçmeli bobin voltajı ve sınırlama
- Standart filtreleme
- Endüstriyel standartlarda kavite
- Kompakt boyut

SYMBOL

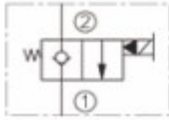

PRESSURE DROP VS. FLOW

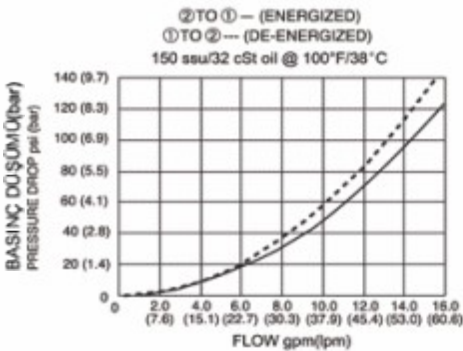

DEBİ (gpm)

SPECIFICATIONS

Max. Operating Pressure : 300Bar

Flow : See PRESSURE DROP VS. FLOW graph.

Internal Leakage : 5 drops/min. max. at 300Bar.

Temperature : -30° F to +250° F (-35°C to +120° C)

Coil Rating : Continuous from 85% to 110% of rated voltage.

Recommended Filtration: Critical Application-ISO 16/12
Non-Critical Application-ISO 19/15

Fluids : Mineral-based fluids.

For other fluid compatibility consult factory.

Cavity : 10-2, see page 265

Body Material : Anodized 6061T6 aluminum
alloy rated at 207 Bar.
Steel rated at 350 Bar.

Hidrosam Hidropar Hidrolik Pnömatik Elektirik San.Tic. Ltd
Alaaddinbey mah. 623 sok. Şam 1 plaza B blok No:2/d Nilüfer/BURSA TURKEY

Tel:+90224 441 8877 Fax:+90224 441 0333

info@hidrosam.com www.hidrosam.com

YERLEŞTİRME ÖLÇÜLERİ INSTALLATION DIMENSIONS

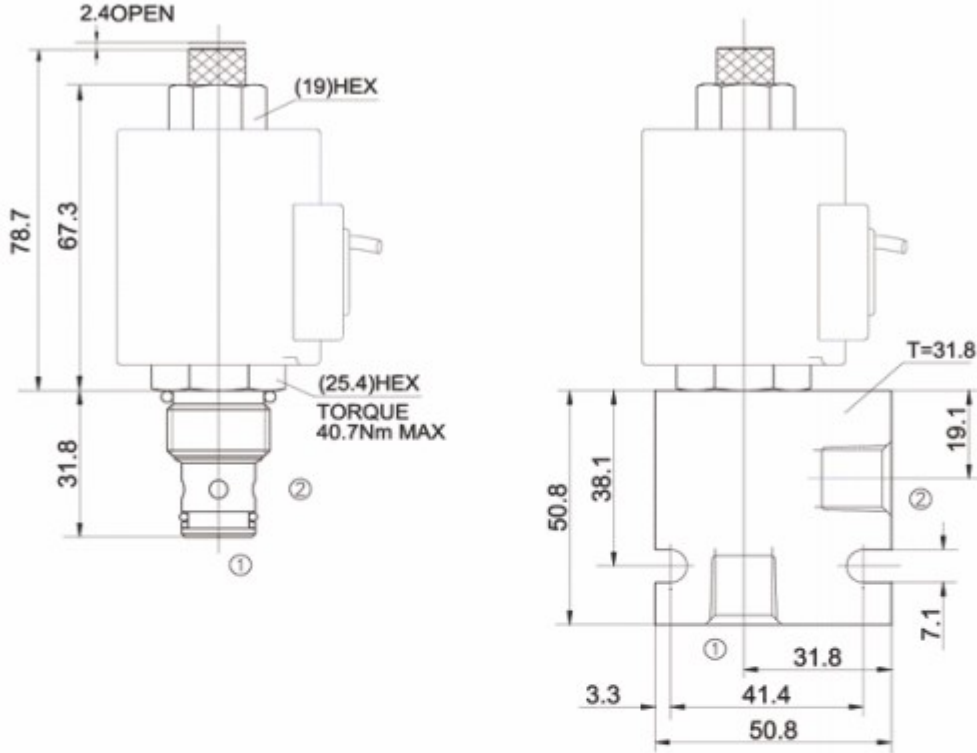

Unit=Millimeters

TO ORDER

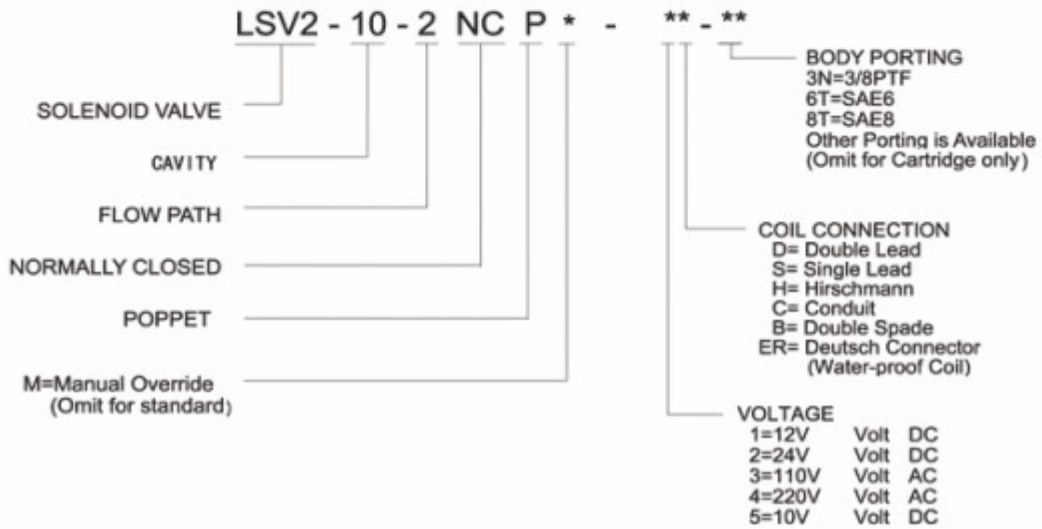

Hidrosam Hidropar Hidrolik Pnömatik Elektrik San.Tic. Ltd
Alaaddinbey mah. 623 sok. Şam 1 plaza B blok No:2/d Nilüfer/BURSA TURKEY
Tel:+90224 441 8877 Fax:+90224 441 0333

info@hidrosam.com www.hidrosam.com