

SOĞUTUCU

HAVALI SOĞUTUCULAR

M

M serisi



MAXTOR SULU SOĞUTUCULARI	$\Delta t=20\text{ }^{\circ}\text{C}$ de	$\Delta t=30\text{ }^{\circ}\text{C}$ de	Maks. Yağ	Maks. Basınç	Yağ-Su bağlantı	Fiyat
	soğutma kcal/saat	kcal/saat	debisi lt/dak	Bar	Ölçüsü	EU/Ad
M6 (230/400 3 FAZ 0,55 KW 1.500 D/D)	26	35	200	26	11/4" BSP	
M8-S (230/400 3 FAZ 2,2 KW 1.500 D/D)	51	72	250	26	11/2" BSP	
M10 (230/400 3 FAZ 5,5 KW 1.500 D/D)	135	180	500	10	SAE 3"	



KOMPRESÖR RADYATÖRLERİ

MA

MAXTOR KOMPRESÖR RADYATÖRLERİ	Güç	Maks. Basınç	Yağ	Hava	Yağ-Su bağlantı	Fiyat
	KW	Bar	mm	mm	Ölçüsü	EU/Ad
MA10021	7,5-11	26	250	90	4x1/2"	
MA10022	11-15	26	285	110	4x1/2"	
MA10023	18-22	26	335	115	2x3/4" - 2x1/2"	
MA10024	30-37	26	455	165	2x11/4" - 2x3/4"	
MA10025	45	26	442	183	2x11/2" - 2x1"	
MA10026	55	26	508	232	2x11/2" - 2x1"	
MA10027	75	26	645	217	2x2" - 2x11/4"	
MA10028	90-110	26	720	300	2x2" - 2x11/4"	
MA10029	132	26	969	421	2x2" - 2x11/2"	
MA10030	160	26	1120	558	2x2" - 2x11/2"	

MA

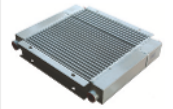

M-SERIES

TECHNICAL DATA



Oil flow lt/min	Heat Difference $\Delta T=30\text{ }^{\circ}\text{C}$ (Oil Heat-Environmental Heat)			Heat Difference $\Delta T=40\text{ }^{\circ}\text{C}$ (Oil Heat-Environmental Heat)		
	M-6 cooling capacity Kcal/h	M-8 cooling capacity Kcal/h	M-10 cooling capacity Kcal/h	M-6 cooling capacity Kcal/h	M-8 cooling capacity Kcal/h	M-10 cooling capacity Kcal/h
50	24080	33540		17200	24080	
75	25800	36120		19780	26660	51600
100	27520	37840	96320	20640	28380	72240
150	29240	41280	110080	21500	30960	82560
200	30100	43000	120400	22360	31820	90300
250		43860	127280		32680	95460
300			134160			100620
400			144480			108360
500			154800			116100

	Oil Connection Size	Max Pressure / bar
M-6	1¼"BSP	26
M-8	1½"BSP	26
M-10	SAE 3"	10

- Tested pressure 36 bar
- Max. working heat 120C
- Italian IMIT TC2 adjustable thermostat is standard

DIMENSIONS FOR M-6 / M-8

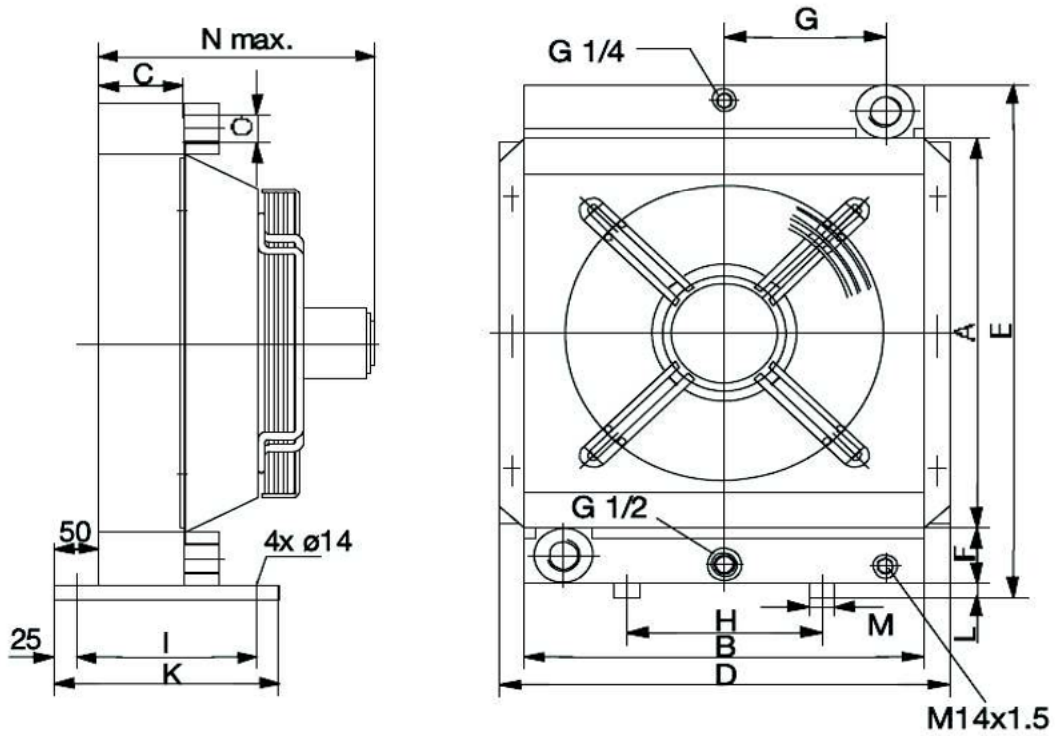

	M-6	M-8
C	94	140
I	250	250
K	300	300
N	450	590

	M-6	M-8
A	650	800
B	557	651
D	607	722
E	790	960
F	60	70
G	235	280
H	310	400
L	20	20
M	50	50

DIMENSIONS FOR M-10

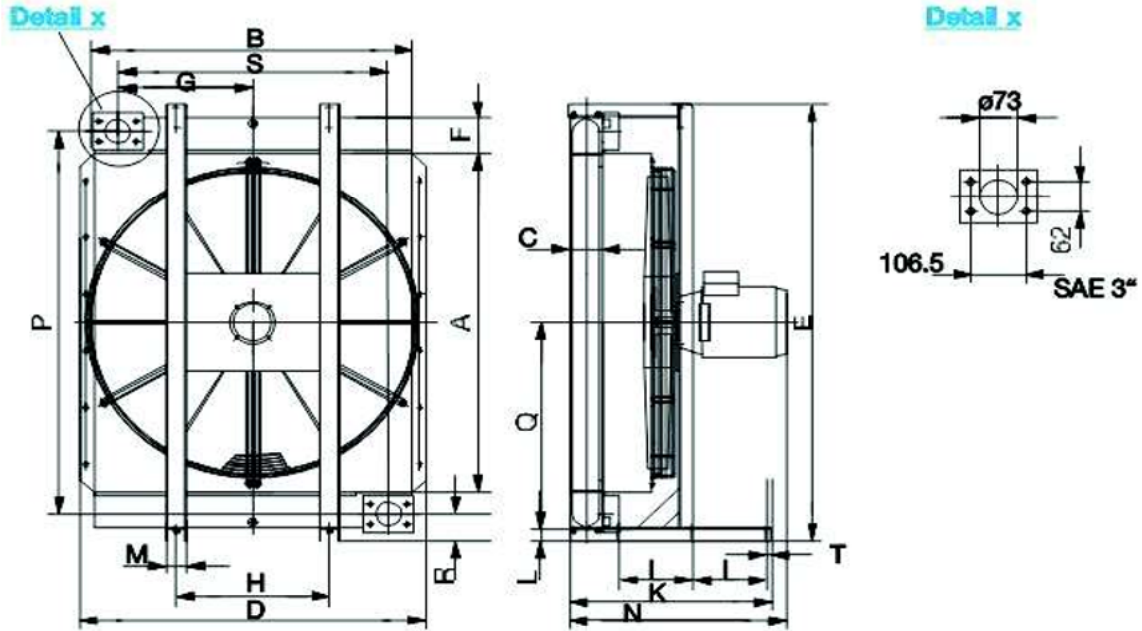

A	1050
B	915
D	995
F	110
G	390
H	440
M	65
P	1182
R	91
S	780

C	115
E	1360
I	215
K	580
L	45
N	700
Q	630
T	15