

SDA



MODEL	ISO SDA SERİSİ MANYETİK SHORT STROK SİLİNDİRLER	Fiyat USD
SDA20X10-S	20X10 SHORT STROK SİLİNDİR MANYETİK	
SDA20X20-S	20X20 SHORT STROK SİLİNDİR MANYETİK	
SDA20X25-S	20X25 SHORT STROK SİLİNDİR MANYETİK	
SDA20X30-S	20X30 SHORT STROK SİLİNDİR MANYETİK	
SDA20X50-S	20X50 SHORT STROK SİLİNDİR MANYETİK	

SDA



MODEL	ISO SDA SERİSİ MANYETİK SHORT STROK SİLİNDİRLER	Fiyat USD
SDA25X10-S	25X10 SHORT STROK SİLİNDİR MANYETİK	
SDA25X20-S	25X20 SHORT STROK SİLİNDİR MANYETİK	
SDA25X25-S	25X25 SHORT STROK SİLİNDİR MANYETİK	
SDA25X30-S	25X30 SHORT STROK SİLİNDİR MANYETİK	
SDA25X50-S	25X50 SHORT STROK SİLİNDİR MANYETİK	

SDA



MODEL	ISO SDA SERİSİ MANYETİK SHORT STROK SİLİNDİRLER	Fiyat USD
SDA 32X10-S	32X10 SHORT STROK SİLİNDİR MANYETİK	
SDA 32X20-S	32X20 SHORT STROK SİLİNDİR MANYETİK	
SDA 32X25-S	32X25 SHORT STROK SİLİNDİR MANYETİK	
SDA 32X30-S	32X30 SHORT STROK SİLİNDİR MANYETİK	
SDA 32X40-S	32X40 SHORT STROK SİLİNDİR MANYETİK	
SDA 32X50-S	32X50 SHORT STROK SİLİNDİR MANYETİK	

SDA



MODEL	ISO SDA SERİSİ MANYETİK SHORT STROK SİLİNDİRLER	Fiyat USD
SDA 40X10-S	40X10 SHORT STROK SİLİNDİR MANYETİK	
SDA 40X20-S	40X20 SHORT STROK SİLİNDİR MANYETİK	
SDA 40X30-S	40X30 SHORT STROK SİLİNDİR MANYETİK	
SDA 40X40-S	40X40 SHORT STROK SİLİNDİR MANYETİK	
SDA 40X50-S	40X50 SHORT STROK SİLİNDİR MANYETİK	

SDA



MODEL	ISO SDA SERİSİ MANYETİK SHORT STROK SİLİNDİRLER	Fiyat USD
SDA 50X10-S	50X10 SHORT STROK SİLİNDİR MANYETİK	
SDA 50X20-S	50X20 SHORT STROK SİLİNDİR MANYETİK	
SDA 50X30-S	50X30 SHORT STROK SİLİNDİR MANYETİK	
SDA 50X40-S	50X40 SHORT STROK SİLİNDİR MANYETİK	
SDA 50X50-S	50X50 SHORT STROK SİLİNDİR MANYETİK	
SDA 50X100-S	50X100 SHORT STROK SİLİNDİR MANYETİK	

MC-11R-1 M	SENSÖR	
------------	--------	--

MC-21R-1 M	SENSÖR	
------------	--------	--

Features

1. Improving for adapting wide range applications, using precise polishing of piston rod, more sense of products quality and longer life of front seal.
2. Adjust the structure to the optimal state, and ensure the smooth operation of the product.
3. The piston rod and the back cover cramping technology, improving product quality.
4. Combined with enterprise color planning, it is redesigned by new color system and precise treatment of particulars.



The back cover cramping



SDA32X5



SDA16X30



SDA50X60-B



SDA25X60-B



SDA50X60

Ordering Code

SDA	20	x	30	-	10	-	S	-	B	-	MT
Series	Bore		Stroke		Adjustable Stroke		Magnet		Thread Type		Sensor
SDA: Double acting	12	16	5-130mm		10: 10mm		S : With magnet		Blank: Female thread		JEL-01R
	20	25			20: 20mm		Blank : Without magnet				
	32	40			30: 30mm						
SSA: Single acting, spring-out	50	63			50: 50mm				B: Male thread		JEL-11R
	80	100			75: 75mm						
					100: 100mm						
STA: Single acting, spring-in											
SDAD: Double-shaft type											
SDAJ : Double-shaft with adjustable stroke											

* Standard wire length is 1 meter, please specify for other length

Specification

Bore (mm)	12	16	20	25	32	40	50	63	80	100
Operation	Double Acting									
	Single Acting Spring-out / Single Acting Spring-in									-
Working Medium	Air									
Operating Pressure Range	Double Acting									
	0.1 ~ 1.0MPa									
Proof Pressure	Single Acting									
	0.2 ~ 0.9MPa									
Operating Temperature Range	1.5 MPa									
	-20 ~ 80 °C									
Operating Speed Range	Double Acting									
	30 ~ 500 mm/s			30 ~ 350 mm/s				30 ~ 250 mm/s		
Port Size	Single Acting									
	50 ~ 500 mm/s					-				
	M5×0.8			G1/8"			G1/4"		G3/8"	

Internal Structure

**SDA Series
Compact Cylinder**

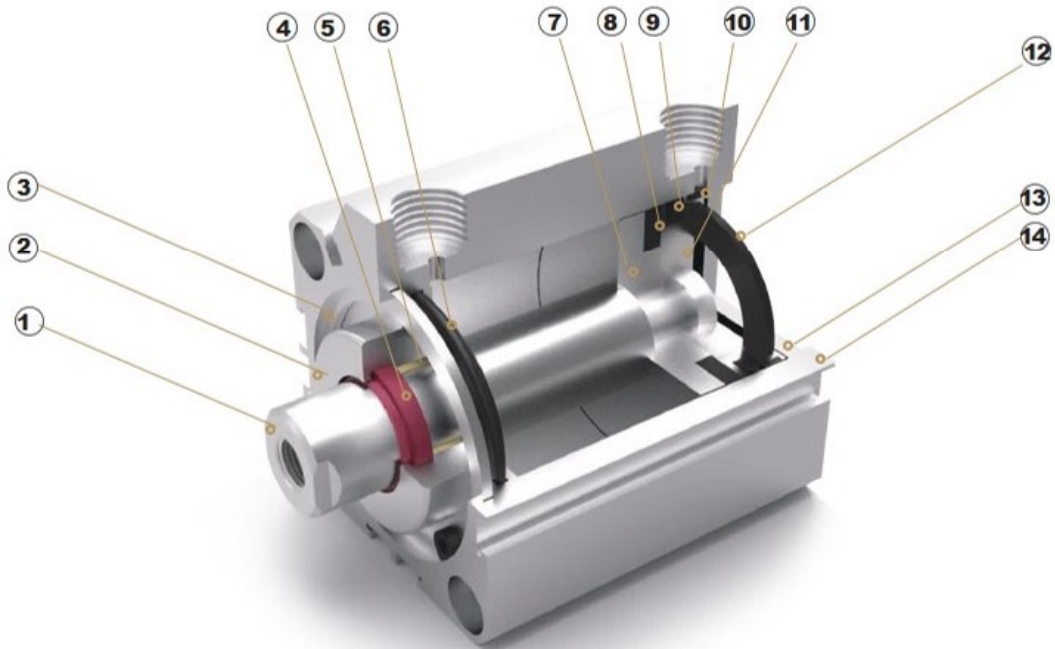

Parts

Number	Name	Number	Name
1	Piston rod	8	Magnet
2	Front cover	9	Piston seal
3	C clip	10	Anti-friction seal
4	Shaft seal	11	Magnet base
5	DU bearing	12	Anti-collision gasket
6	O ring	13	Back cover
7	Piston	14	Body

SDA Series
Compact Cylinder

Overall Dimension

SDA12-16 Female thread

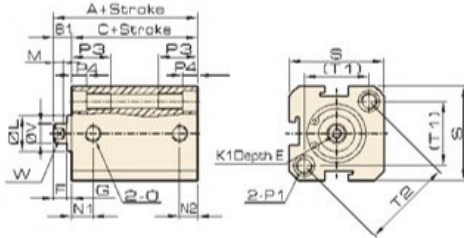

SDA20-100 Female thread

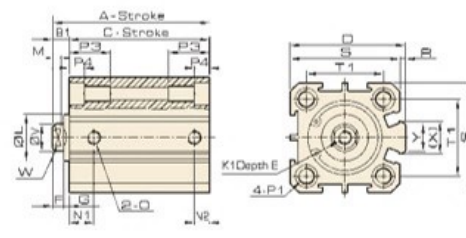

SDA12-16 Male thread

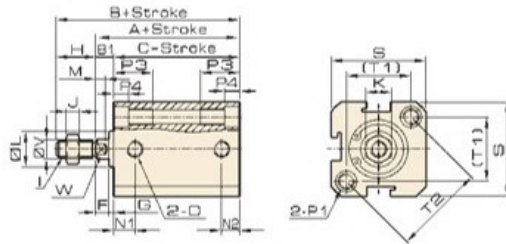

SDA20-100 Male thread

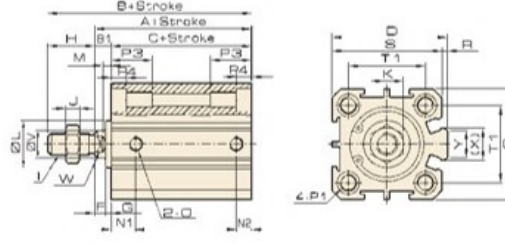

Dimension

Bore/ Symbol	A		B		C		B1	D	E	F	G	H	I	J	K	K1	L	M
	Standar	With magnet	Standar	With magnet	Standar	With magnet												
12	22	32	34	44	17	27	5	-	6	4	2	12	M5×0.8	4	8	M3×0.5	10	3
16	24	34	36	46	18.5	28.5	5.5	-	6	4	2	12	M5×0.8	4	8	M3×0.5	11	3
20	25	35	40	50	19.5	29.5	5.5	36	8	4	1.5	15	M6×1.0	5	10	M4×0.7	13	3
25	27	37	44	54	21	31	6	42	10	4	2	17	M8×1.25	6	14	M5×0.8	17	3
32	31.5	41.5	49.5	59.5	24.5	34.5	7	50	12	4	3	18	M10×1.25	6	17	M6×1.0	22	3
40	33	43	61	71	26	36	7	58.5	12	4	3	28	M14×1.5	8	22	M8×1.25	28	3
50	37	47	65	75	28	38	9	71.5	15	5	4	28	M18×1.5	9	27	M10×1.5	38	3
63	41	51	69	79	32	42	9	84.5	15	5	4	28	M18×1.5	9	27	M10×1.5	40	3
80	52	62	85	95	41	51	11	104	20	6	5	33	M22×1.5	13	32	M14×1.5	45	4
100	63	73	101	111	51	61	12	124	20	7	5	38	M26×1.5	12	36	M18×1.5	55	4

Bore/ Symbol	N1		N2		O	P1	P3	P4	R	S	T1	T2	V	W	X	Y
	S=5	S>5	S=5	S>5												
12	7.5	5			M5×0.8	Double Side: Φ6.5, Cog: M5×0.8, Through Hole: Φ4.2	12	4.5	-	25	16.3	23	6	5	-	-
16	8	5	5.5		M5×0.8	Double Side: Φ6.5, Cog: M5×0.8, Through Hole: Φ4.2	12	4.5	-	29	19.8	28	6	5	-	-
20	8.5		5.5		M5×0.8	Double Side: Φ6.5, Cog: M5×0.8, Through Hole: Φ4.2	14	4.5	2	34	24	-	8	6	11.2	10
25	9		5.5		M5×0.8	Double Side: Φ8.2, Cog: M6×1, Through Hole: Φ4.6	15	5.5	2	40	28	-	10	8	12	10
32	9	6.5	8		G1/8	Double Side: Φ8.2, Cog: M6×1, Through Hole: Φ4.6	16	5.5	6	44	34	-	12	10	18	14
40	9		7.5		G1/8	Double Side: Φ10, Cog: M8×1.25, Through Hole: Φ6.7	20	7.5	6.5	52	40	-	16	14	21	14
50	8	10.5	8	10.5	G1/4	Double Side: Φ11, Cog: M8×1.25, Through Hole: Φ6.7	25	8.5	9.5	62	48	-	20	17	29.5	19
63	9.5	11	9.5	11	G1/4	Double Side: Φ11, Cog: M8×1.25, Through Hole: Φ6.7	25	8.5	9.5	75	60	-	20	17	26	19
80	11.5	14	11.5	14	G3/8	Double Side: Φ15, Cog: M12×1.75, Through Hole: Φ10.3	25	10.5	10	94	74	-	25	22	36	26
100	15	20	15	18	G3/8	Double Side: Φ17.5, Cog: M14×2, Through Hole: Φ11.3	30	13	10	114	90	-	32	27	35.5	26

SDA Series
Compact Cylinder

Overall Dimension

SDAD20-100 Female thread

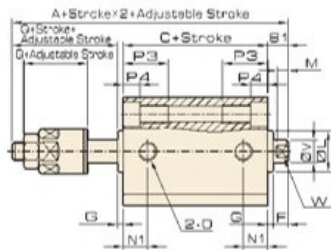
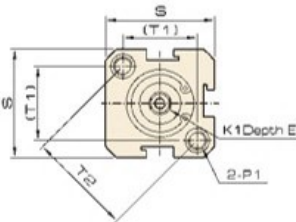

SDAJ12-16 Female thread



SDAD20-100 Male thread

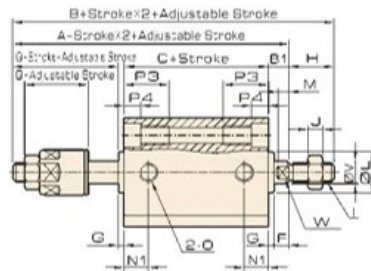
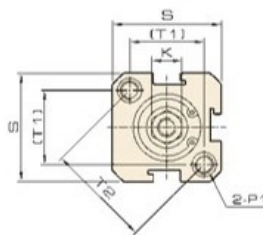

SDAJ12-16 Male thread



Dimension

Bore/ Symbol	A		B		C		B1	D	E	F	G	H	I	J	K	K1	L	M	N1	
	Standard	With magne	Standard	With magne	Standard	With magne													S=5	S>5
12	41	51	53	63	17	27	5	-	6	4	2	12	M5x0.8	4	8	M3x0.5	10	3	5.5	6.5
16	43	53	55	65	18.5	28.5	5.5	-	6	4	2	12	M5x0.8	4	8	M3x0.5	11	3	6.5	7.5
20	47.5	57.5	62.5	72.5	19.5	29.5	5.5	36	8	4	1.5	15	M6x1.0	5	10	M4x0.7	13	3	-	7.5
25	53	63	70	80	21	31	6	42	10	4	2	17	M8x1.25	6	14	M5x0.8	17	3	-	8
32	61.5	71.5	79.5	89.5	24.5	34.5	7	50	12	4	3	18	M10x1.25	6	17	M6x1.0	22	3	8	9
40	64	74	92	102	26	36	7	58.5	12	4	3	28	M14x1.5	8	22	M8x1.25	28	3	8	10
50	70	80	98	108	28	38	9	71.5	15	5	4	28	M18x1.5	9	27	M10x1.5	38	3	8	10.5
63	74	84	102	112	32	42	9	84.5	15	5	4	28	M18x1.5	9	27	M10x1.5	40	3	9.5	11
80	92.5	102.5	125.5	135.5	41	51	11	104	20	6	5	33	M22x1.5	13	32	M14x1.5	45	4	11.5	14
100	110.5	120.5	148.5	158.5	51	61	12	124	20	7	5	38	M26x1.5	12	36	M18x1.5	55	4	15	20

Bore/ Symbol	O	P1	P3	P4	Q	R	S	T1	T2	V	W	X	Y
12	M5x0.8	Double Side: Φ 6.5, Cog: M5x0.8, Through Hole: Φ 4.2	12	4.5	17	-	25	16.3	23	6	5	-	-
16	M5x0.8	Double Side: Φ 6.5, Cog: M5x0.8, Through Hole: Φ 4.2	12	4.5	17	-	29	19.8	28	6	5	-	-
20	M5x0.8	Double Side: Φ 6.5, Cog: M5x0.8, Through Hole: Φ 4.2	14	4.5	21	2	34	24	-	8	6	11.2	10
25	M5x0.8	Double Side: Φ 8.2, Cog: M6x1, Through Hole: Φ 4.6	15	5.5	24	2	40	28	-	10	8	12	10
32	G1/8	Double Side: Φ 8.2, Cog: M6x1, Through Hole: Φ 4.6	16	5.5	27	6	44	34	-	12	10	18	14
40	G1/8	Double Side: Φ 10, Cog: M8x1.25, Through Hole: Φ 6.7	20	7.5	28	6.5	52	40	-	16	14	21	14
50	G1/4	Double Side: Φ 11, Cog: M8x1.25, Through Hole: Φ 6.7	25	8.5	29	9.5	62	48	-	20	17	29.5	19
63	G1/4	Double Side: Φ 11, Cog: M8x1.25, Through Hole: Φ 6.7	25	8.5	29	9.5	75	60	-	20	17	26	19
80	G3/8	Double Side: Φ 15, Cog: M12x1.75, Through Hole: Φ 10.3	25	10.5	35.5	10	94	74	-	25	22	36	26
100	G3/8	Double Side: Φ 17.5, Cog: M14x2, Through Hole: Φ 11.3	30	13	42.5	10	114	90	-	32	27	35.5	26

Overall Dimension

SDA Series
Compact Cylinder

SDAJ20-100 Female thread

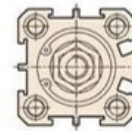
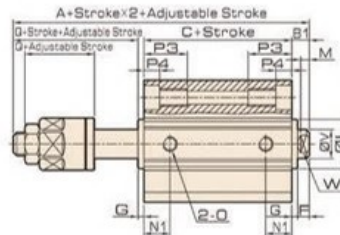
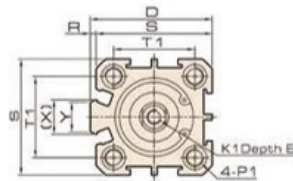

SDAJ20-100 Male thread

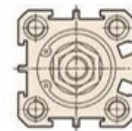
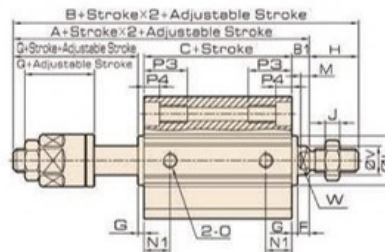
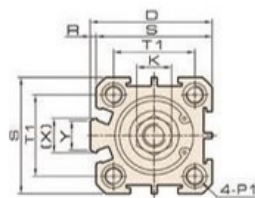

Dimension

Bore/ Symbol	A		B		C		B1	D	E	F	G	H	I	J	K	K1	L	M	N1	
	Standard	With magnet	Standard	With magnet	Standard	With magnet													S=5	S=5
12	41	51	53	63	17	27	5	-	6	4	2	12	M5×0.8	4	8	M3×0.5	10	3	5.5	6.5
16	43	53	55	65	18.5	28.5	5.5	-	6	4	2	12	M5×0.8	4	8	M3×0.5	11	3	6.5	7.5
20	47.5	57.5	62.5	72.5	19.5	29.5	5.5	36	8	4	1.5	15	M6×1.0	5	10	M4×0.7	13	3	7.5	
25	53	63	70	80	21	31	6	42	10	4	2	17	M8×1.25	6	14	M5×0.8	17	3	8	8
32	61.5	71.5	79.5	89.5	24.5	34.5	7	50	12	4	3	18	M10×1.25	6	17	M6×1.0	22	3	8	9
40	64	74	92	102	26	36	7	58.5	12	4	3	28	M14×1.5	8	22	M8×1.25	28	3	8	10
50	70	80	98	108	28	38	9	71.5	15	5	4	28	M18×1.5	9	27	M10×1.5	38	3	8	10.5
63	74	84	102	112	32	42	9	84.5	15	5	4	28	M18×1.5	9	27	M10×1.5	40	3	9.5	11
80	92.5	102.5	125.5	135.5	41	51	11	104	20	6	5	33	M22×1.5	13	32	M14×1.5	45	4	11.5	14
100	110.5	120.5	148.5	158.5	51	61	12	124	20	7	5	38	M26×1.5	12	36	M18×1.5	55	4	15	20

Bore/ Symbol	O	P1		P3	P4	Q	R	S	T1	T2	V	W	X	Y
		Double Side	Cog											
12	M5×0.8	Double Side: Φ6.5, Cog: M5×0.8, Through Hole: Φ4.2		12	4.5	17	-	25	16.3	23	6	5	-	-
16	M5×0.8	Double Side: Φ6.5, Cog: M5×0.8, Through Hole: Φ4.2		12	4.5	17	-	29	19.8	28	6	5	-	-
20	M5×0.8	Double Side: Φ6.5, Cog: M5×0.8, Through Hole: Φ4.2		14	4.5	21	2	34	24	-	8	6	11.2	10
25	M5×0.8	Double Side: Φ8.2, Cog: M6×1, Through Hole: Φ4.6		15	5.5	24	2	40	28	-	10	8	12	10
32	G1/8	Double Side: Φ8.2, Cog: M6×1, Through Hole: Φ4.6		16	5.5	27	6	44	34	-	12	10	18	14
40	G1/8	Double Side: Φ10, Cog: M8×1.25, Through Hole: Φ6.7		20	7.5	28	6.5	52	40	-	16	14	21	14
50	G1/4	Double Side: Φ11, Cog: M8×1.25, Through Hole: Φ6.7		25	8.5	29	9.5	62	48	-	20	17	29.5	19
63	G1/4	Double Side: Φ11, Cog: M8×1.25, Through Hole: Φ6.7		25	8.5	29	9.5	75	60	-	20	17	26	19
80	G3/8	Double Side: Φ15, Cog: M12×1.75, Through Hole: Φ10.3		25	10.5	35.5	10	94	74	-	25	22	36	26
100	G3/8	Double Side: Φ17.5, Cog: M14×2, Through Hole: Φ11.3		30	13	42.5	10	114	90	-	32	27	35.5	26

SDA Series Compact Cylinder

Overall Dimension

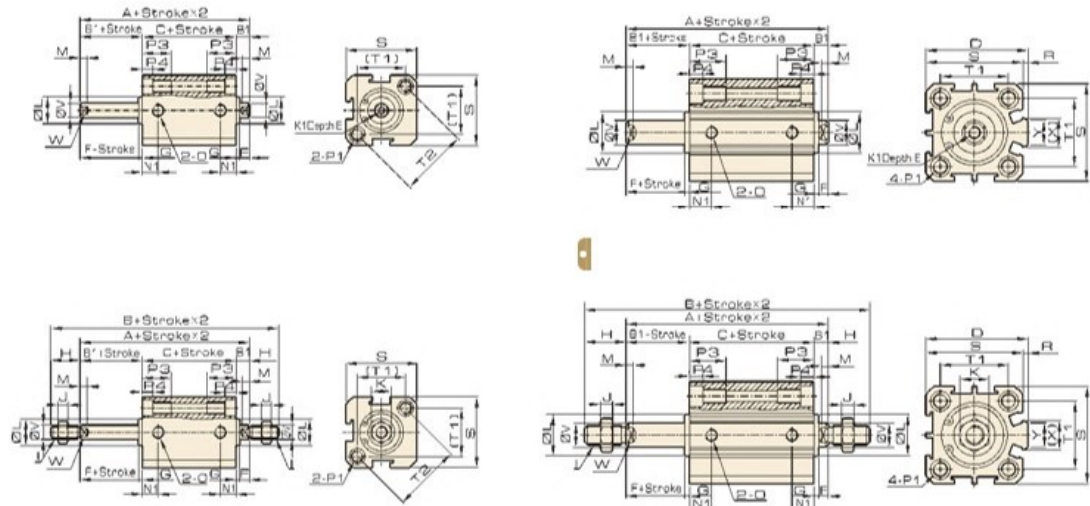

Dimension

Bore/ Symbol	A		B		C		B1	D	E	F	G	H	I	J	K	K1	L	M	N1	
	Standard	With magnet	Standard	With magnet	Standard	With magnet													S=5	S>5
12	27	37	51	61	17	27	5	-	6	4	2	12	M5×0.8	4	8	M3×0.5	10	3	5.5	6.5
16	29.5	39.5	53.5	63.5	18.5	28.5	5.5	-	6	4	2	12	M5×0.8	4	8	M3×0.5	11	3	6.5	7.5
20	30.5	40.5	60.5	70.5	19.5	29.5	5.5	36	8	4	1.5	15	M6×1.0	5	10	M4×0.7	13	3	7.5	
25	33	43	67	77	21	31	6	42	10	4	2	17	M8×1.25	6	14	M5×0.8	17	3	8	
32	38.5	48.5	74.5	84.5	24.5	34.5	7	50	12	4	3	18	M10×1.25	6	17	M6×1.0	22	3	8	9
40	40	50	96	106	26	36	7	58.5	12	4	3	28	M14×1.5	8	22	M8×1.25	28	3	8	10
50	46	56	102	112	28	38	9	71.5	15	5	4	28	M18×1.5	9	27	M10×1.5	38	3	8	10.5
63	50	60	106	116	32	42	9	84.5	15	5	4	28	M18×1.5	9	27	M10×1.5	40	3	9.5	11
80	63	73	129	139	41	51	11	104	20	6	5	33	M22×1.5	13	32	M14×1.5	45	4	11.5	14
100	75	85	151	161	51	61	12	124	20	7	5	38	M26×1.5	12	36	M18×1.5	55	4	15	20

Bore/ Symbol	O	P1	P3	P4	R	S	T1	T2	V	W	X	Y
12	M5×0.8	Double Side: Φ6.5, Cog: M5×0.8, Through Hole: Φ4.2	12	4.5	-	25	16.3	23	6	5	-	-
16	M5×0.8	Double Side: Φ6.5, Cog: M5×0.8, Through Hole: Φ4.2	12	4.5	-	29	19.8	28	6	5	-	-
20	M5×0.8	Double Side: Φ6.5, Cog: M5×0.8, Through Hole: Φ4.2	14	4.5	2	34	24	-	8	6	11.2	10
25	M5×0.8	Double Side: Φ8.2, Cog: M6×1, Through Hole: Φ4.6	15	5.5	2	40	28	-	10	8	12	10
32	G1/8	Double Side: Φ8.2, Cog: M6×1, Through Hole: Φ4.6	16	5.5	6	44	34	-	12	10	18	14
40	G1/8	Double Side: Φ10, Cog: M8×1.25, Through Hole: Φ6.7	20	7.5	6.5	52	40	-	16	14	21	14
50	G1/4	Double Side: Φ11, Cog: M8×1.25, Through Hole: Φ6.7	25	8.5	9.5	62	48	-	20	17	29.5	19
63	G1/4	Double Side: Φ11, Cog: M8×1.25, Through Hole: Φ6.7	25	8.5	9.5	75	60	-	20	17	26	19
80	G3/8	Double Side: Φ15, Cog: M12×1.75, Through Hole: Φ10.3	25	10.5	10	94	74	-	25	22	36	26
100	G3/8	Double Side: Φ17.5, Cog: M14×2, Through Hole: Φ11.3	30	13	10	114	90	-	32	27	35.5	26