

The operation manual for VT-3000BS30

proportional amplifier VT-3000BS30 is used in the control of pilot 3-position, 4-way proportional valve 4WRZ10(16,25,32) ... --30/24, pilot pressure reduce valve 3DREP6 ... --10/24.

I. Technical data:

1. Power supply: 24V +10%-5%
2. Power: 40W
3. Control voltage:  $\pm 9V \pm 2\%$
4. Max. output current: 800mA
5. Pilot current: no more than 20MA
6. Load resistant: 19--24  $\Omega$
7. Ramp time: 0.02S-5S
8. Ambient temperature: 0-40°C
9. Stability:  $\pm 8mA/8h$
10. Temperature drift: 0.5‰ (1max.)°C

Remark: if you have special requirement, please tell us when ordering

II. Output Characteristic: Refer to (Scheme 1)

III. How to use: Refer to connecting diagram

• Amplifier and external wiring connection

1. The electrical supply should be D.C.24V

The point 32A or 32C connected to the positive pole of the electrical supply. 26A or 26C connected to the negative pole of the electrical supply.

2. The connection of between the amplifier and solenoid.

The two ports of the proportional solenoid A should be connected to 30A and 24 A separately.

The two ports of the proportional solenoid B should be connected to 28A and 22A separately.

Remark: there is no directionality in the wire connecting.

3. The input of the control voltage signal

(1). 4 manual input ports for the input of voltage can be preset

a. When you use preset potentiometer P1 to input  $\pm 9V$  electric signal, 10C is signal input end, Switch on relay K1. It means short-circuit 28C(+24V) and 8C.

b. When you use preset potentiometer P2 to input  $\pm 9V$  electric signal, 10A is signal input end, Switch on relay K2. It means short-circuit 28C(+24V) and 4A.

c. When you use preset potentiometer P3 to input  $\pm 9V$  electric signal, 8A is signal input end, Switch on relay K3. It means short-circuit 28C(+24V) and 6A.

d. When you use preset potentiometer P4 to input  $\pm 9V$  electric signal, 12A is signal input end, Switch on relay K4. It means short-circuit 28C(+24V) and 6C.

The for input end is optional, while P4(12A) is preferential

Remark: when you choose one of the input port, the relevant red LED will light to indicate it is the currently input port.

4. 0 -  $\pm 10V$  differential motion voltage input end wire connection.

Select 0-  $\pm 10V$  differential motion voltage signal, input the signal from 16A and 16C. The amplifier can automatically control the current of the proportional solenoid. In order to attain the maximum current 800mA, differential motion voltage value should up to  $\pm 10V$

Remark: All the input cable should be shield wire, if possible.

- The usage of the amplifier
1. There are 9V(20C) and -9V(26A or 26C) voltage for manual input signal. Positive signal control solenoid B, negative signal control A.  
There are two control patterns:
    - a. To preset potentiometer (P1-P4), choose the different circuit according to the programming.
    - b. Manual regulated (Refer scheme 3 and scheme 4)
  2. The  $\pm 10V$  differential motion signal from program controller (PLC) and function generator input from 16A and 16C, when the electric potential of 16A higher than 16C, the solenoid B working; when the electric potential of 16A lower than 16C, solenoid A working. When the differential motion signal change from 0 to  $\pm 10V$ , the proportional valve accordingly have the current from 0-800mA to drive solenoid. The current can be regulated smoothly and convenient.  
Caution: never connect 16A or 16C to 20A(MO) or the negative of the 24VDC power 26A, 26C. It means the program controller and the proportional amplifier can not use the one power.
  3. The current value of the solenoid can be measured from the instrument connection BU2 and BU3. The voltage value measured from the DC voltage meter (mV) is approximate the current value of the solenoid (mA).
  4. The potentiometer P9 is used to adjust the ramp time. If the system do not need the delay time, you can counterclockwise rotate the potentiometer to the end, or short circuit 14A and 14C, or put through K5
- This amplifier use European standard (5.08X5.08mm) to connect the plug-in unit. VT-3002B holder can match with this amplifier

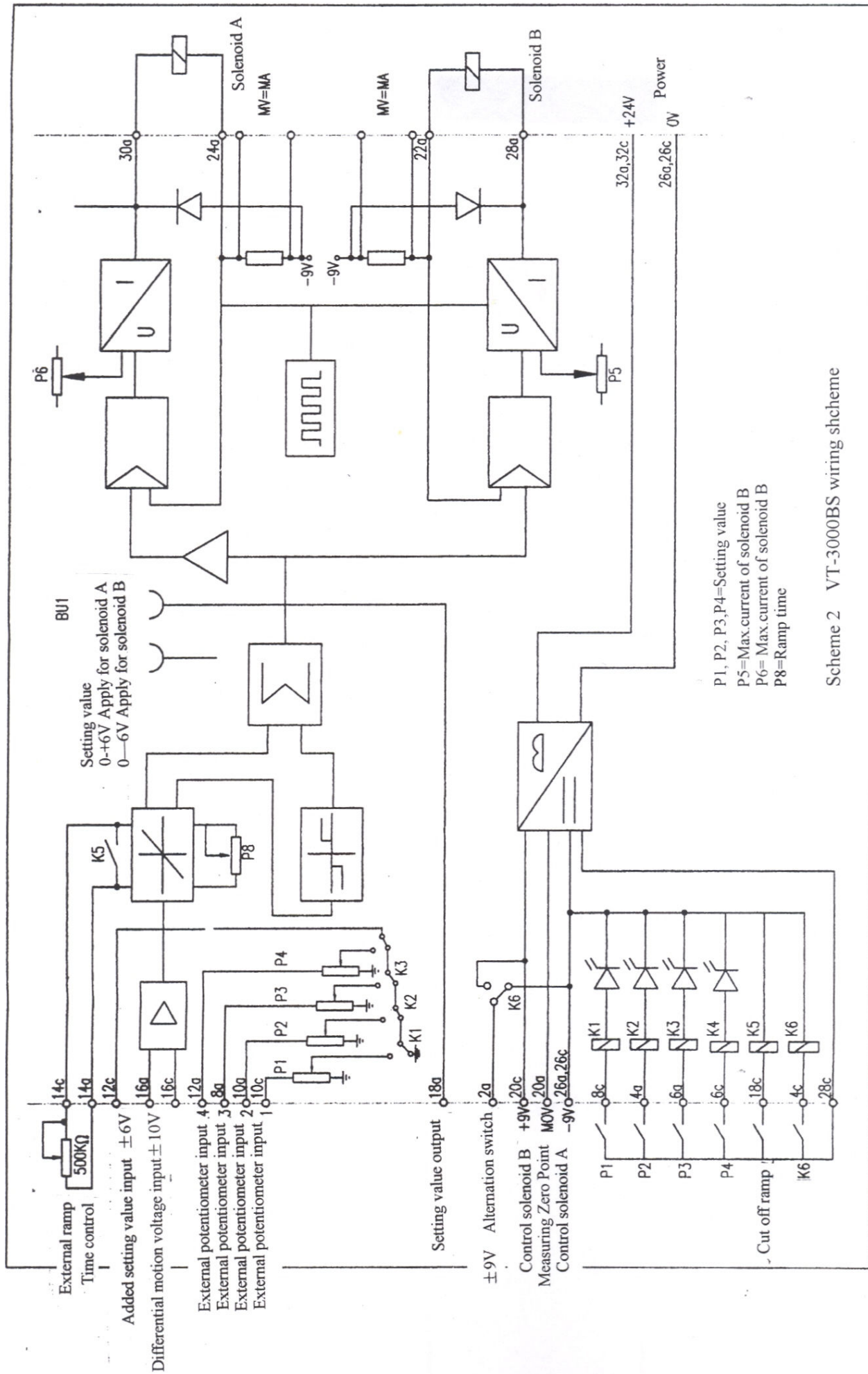

P1, P2, P3, P4=Setting value  
 P5=Max.current of solenoid B  
 P6= Max.current of solenoid B  
 P8=Ramp time

Scheme 2 VT-3000BS wiring shcheme

