

IR Serisi Hassas Regülatör / IR Series Precision Regulator



Özellikler / Specification

Model / Model	IR3000-02	IR3010-02	IR3020-02
Akışkan / Fluid	Hava / Air		
Bağlantı Ölçüsü / Port Size	1/4"		
Hassasiyet / Precision	Tüm değerler içinde %0.2 / Within %0.2 of full span		
Basınç Aralığı / Pressure Range	0.05 - 2 bar	0.05 - 4 bar	0.05 - 8 bar
Max. Çalışma Basıncı / Max. Pressure	10.0bar / 1.0MPa / 142Psi		
Test Basıncı / Proof Pressure	15.0bar / 1.5MPa / 213Psi		
Sıcaklık / Temperature	5~60°C		
Debi / Flow	1100 L/dak - L/min		
Hava Tüketimi / Air Consumption	4 L/dak' dan daha az (1.0MPa) / Less than 4 L/min (1.0MPa)		

Sembol / Symbol

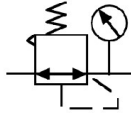

Teknik Çizimler / Technical Drawings

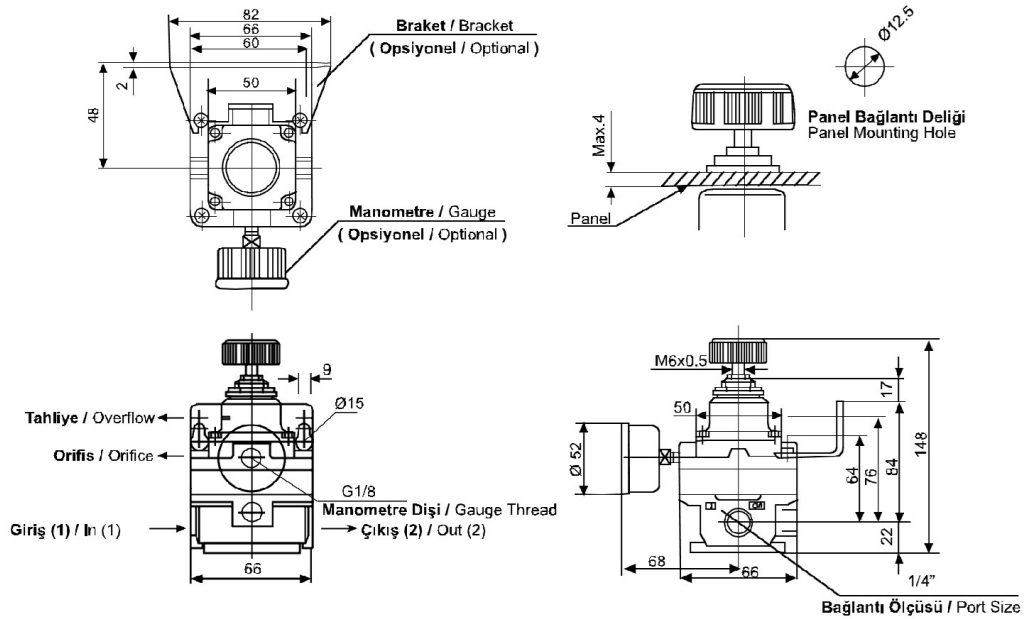

Sipariş Kodu / Ordering Code

IR30	10	□	02	B	R
Model / Model	Basınç / Pressure	Diş Tipi / Thread	Bağlantı / Port	Aksesuarlar / Accessories	Manometre / Gauge
IR30: Hassas Regülatör / Precision Regulator	00: 0.05 ~ 2.0 bar	Boş / Blank: G N: NPT	02: 1/4"	Boş / Blank: Yok / None	Boş / Blank: Normal R: Ters Yön / Reverse Side
	10: 0.05 ~ 4.0 bar			B: Braketli / With Bracket	
	20: 0.05 ~ 8.0 bar			G: Manometreli / With Gauge	